

F4000 Intelligent Control System of
Flat Knitting Machine

Operation Manual

V2.0



Welcome to WeChat public number

**Raynen Knitting
Intelligent Control**

For more services and information

RAYNEN TECHNOLOGY CO., LTD.

 National Hotline
400-102-9696

Add: Bldg 26, Block C, Software Park, No. 89, Software Rd., Gulou District, Fuzhou, Fujian

Tel: (86) 591 8826 7288 Fax: (86) 591 8826 7299

E-mail: sales@raynen.cn www.raynen.cn

Copyright © 2015 Raynen Technology Co., Ltd. All rights reserved.



Raynen 睿能®



Thanks for your purchase

Thanks for your purchase of the company's own research and development efforts to create the automatic computerized flat knitting machine. Before you use the machine to go through the proper training and carefully read the operating manual Familiar with the computerized flat knitting machine before use When you read this manual, please follow the instructions and steps of manual operation.

Please pay attention to the "Handling Precautions", "pay attention", "warning" messages, in order to maintain the normal operation of the machine.



Content

Content	1
Machine main parts and operational procedure	3
1. Main parts.....	3
Touch Screen	3
Control lever.....	3
Emergency stop switch.....	4
2. Key tips	4
Operation procedure	5
Pattern preparation	5
Parameter setting	5
Working confirmed.....	5
Machine running	5
Specification and Parameter.....	6
Main features and functions	6
Safety Precautions	7
1. Supply and environmental conditions	7
2. Operation guide	8
3. Repair and maintenance specifications	8
Operation Manual.....	9
1. Starting Interface	9
1.1. A Factory Logo	9
1.2. B Help	9
1.3. C Shutdown	10
1.4. D Import Start Logo.....	10
1.5. E Import knitting Logo	10
2. Running Interface	10
2.1. Running monitor screen display description	11
2.2. Function key F1~F6 Explanation on the running interface	12
3. System Function Interface.....	16
3.1. Pattern Edit	16
3.1.1. Program Edit	16
3.1.2. Pattern Edit	17
3.1.3. Carriers swap/replace.....	18
3.1.4. Cycle	18
3.2. Working parameters	19
3.2.1. Normal Parameters	19
3.2.2. Yarn Speed Correction	22
3.3. System Parameters.....	23
3.3.1. System parameters	23
3.3.2. Racking	33
3.3.3. Transfer Racking.....	34

3.3.4. Density Correction.....	35
3.3.5. Double Density	35
3.3.6. Comb.....	36
3.4. Check	42
3.4.1. Output Testing.....	42
3.4.2. Input Testing	44
3.4.3. Carriage Testing.....	47
3.4.4. Comb Testing.....	48
3.4.5. Voltage Testing.....	49
3.5. File	49
3.5.1. File Management	49
3.5.2. Knitting Plan	50
3.5.3. Parameters management	51
3.5.4. Produce Information	52
3.5.5. Parameters Copy	53
3.5.6. Net Pattern	53
3.6. Machine	54
3.6.1. Senior Parameters	54
3.6.2. Internet Setting.....	56
3.6.3. Upgrade.....	57
3.6.4. Machine Setting (Payment by installment).....	58
3.6.5. Machine Configuration.....	58
3.6.6. Select Language.....	65
Common fault table.....	66
Appendix I.....	69
1. Set total pulses through the carriage position.....	69
2. Set Needle Origin position through the carriage position	69
Appendix II knitting principle.....	70
1. Needle structure and needle selection corresponds to the selected pin relation.....	70
2. Carriage cam structure (dual system).....	71
3. The cam action and needle channel direction	72
3.1 Knitting.....	72
3.2 Non-knitting.....	73
3.3 Transfer, Receive	73
3.4 One of the dual system knit and the other get	74

Machine main parts and operational procedure

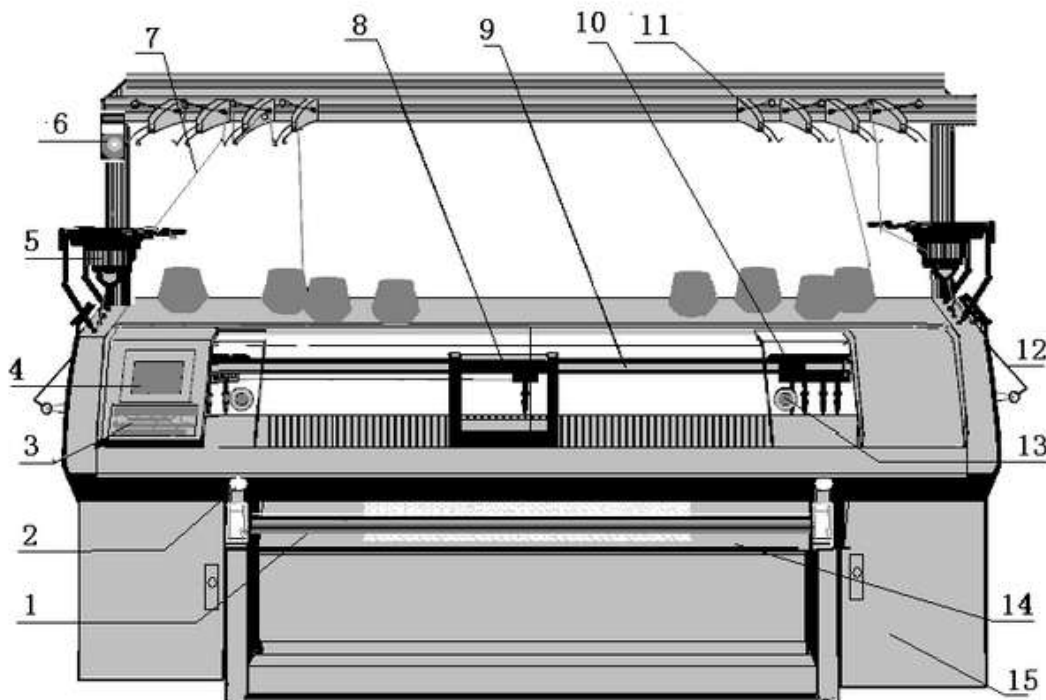

1 Control lever	2 emergency stop switch	3 keys	4 touch screen	5 Yarn Storage
6 signal light	7 yarn	8 Carriage	9 carrier rail	10 carrier
11 tension equipment	12 side tension equipment	13 front protective cover	14、 comb	15 Side Cabinet

1. Main parts

Touch Screen Good operation environment, user-friendly operation. You can input data, operate machine and perform other functions by clicking the function buttons on the touch screen

 **Note:** Do not click on the touch screen with sharp object. Otherwise it will cause damage to the touch screen. Recommend using the touch pen

Control lever Control lever is to control the computerized flat knitting machine carriage stop, low-speed and high-speed operation, the operating methods are:

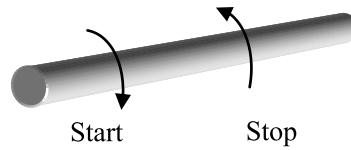

- Low-speed: Turn the control lever clockwise 45 degrees, when the buzzer sounds heard, release the control lever, then the machine carriage start and move slowly, the speed setting will be described later.
- High-speed: Turn the control lever clockwise to the limit, when the buzzer sounds heard, release the control lever, now the machine carriage running in a high speed, the speed setting will be described later.
- Stop: Turn the control lever counterclockwise to the limit, this time the machine carriage stop running.
-

Emergency stop switch You can rotate the emergency stop switch so that it will bounce. At this time, you can operate the machine carriage by control lever

2. Key tips

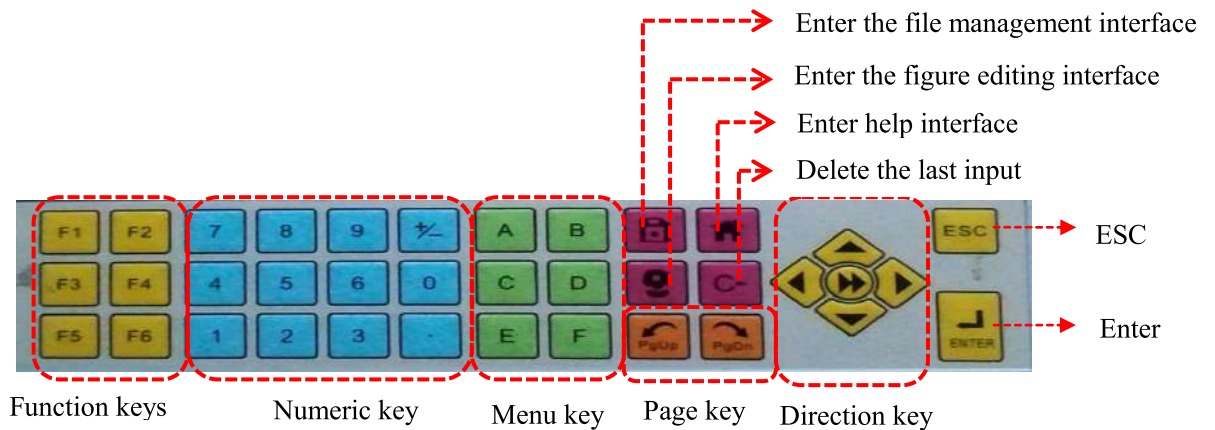

Operation procedure

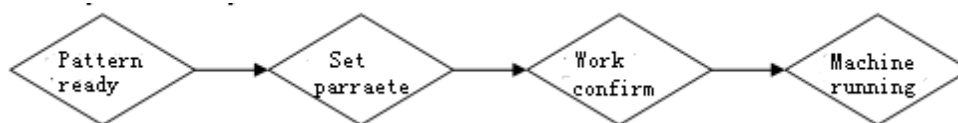

Pattern preparation: A version of the system will be compiled pattern file input to the computer machine memory, if necessary modify the machine in the computer and save.

Parameter setting:

- System parameters: Parameter setting: Each computerized flat knitting machine has one custom set of parameters according to their own determined mechanical features, such as needle zero position, needle bed length etc. These parameters have been tested well when the machine leave factory. And the parameters generally not need to be modified by the users. If need to be changed, it must be only by professionals.
- Working parameters: The parameters are the one which computerized flat knitting machine will use according to the work required, such as the start needle position, sinker position etc.
- Knitting parameters: A series parameters closely related with the knitting patterns, Including speed, roller speed, stitch value etc. These parameters will be modified by the user according to the different patterns, wool etc. technological process requirements.

(Note: Knitting parameters can be saved to memory after knitting one time, when the pattern is saved to USB disk. The parameter will also be kept together)

Working confirmed: Final confirmation for the pattern program to be knitted, each parameters, mechanical normal operation etc.

Machine running: After finishing the above work, use the control lever to start the computerized flat knitting machine to knit

Specification and Parameter

Knitting Speed	Max:1.4m/s
Yarn feeder	8x4
Carriage	single system , Double system、 three system、 1+1system、 2+2 system
Cam system configuration	Electromagnet, motor
Gauge	3.5 Gauge, 5 Gauge, 7 Gauge, 9 Gauge, 12 Gauge, 14 Gauge, 16 Gauge, 18 Gauge,
Racking	one side racking, double side racking, double motor and double side racking
Needle select device	3, 4, 6, 8, 10section(bi-directional self-holding), 6 section (unidirectional) Electromagnetic needle selection, single needle selection
Density	Stepper Motor Driver, support that each motor Independently control
Needle bed movement	Servo motor drive, : left,、 right:1 inch, motor AC220V750W
Main roller	Stepper motor drive, Toque motor drive
Comb	Toque motor drive
Self-stop device	Emergency stop, prevent crush, Yarn broken, yarn knot, cloth fall off, needle broken, floating stitch, rewind cloth, cloth piece number finished, Density motor lose step etc.
Basic function	Knitting, transfer, tuck, receive, pointelle, slip stitch, Jacquard, Intarsia etc.
Main motor	Servo motor AC220V 1000w, AC220V/1500W, rotation rate 1000rpm
Storage	96MB

Main features and functions

The fully automatic small computerized flat knitting machine control system will turn your design into reality through the knitting pattern file made by pattern system, The machine has the following features and functions:

- Support the function of multi piece knitting and automatic comb. The pattern doesn't need to be modified.
- Support the function of continuous knitting plan. Multiple patterns continuously knit and count according to the plan.
- Supports 32 yarns, the pattern is More refined, the efficiency is higher
- Accurately control density, Supports dynamic density.
- Support that lock single system to knit
- Support that carriage rapidly returns, the running efficiency of the carriage is higher.
- Support that machine continuously knit after power failure

- Configuration technology of the cordwood module. Carriage controller, operation box, servo driver, comb controller can be selected.
- Support multiple languages.
- It is compatible with mainstream pattern file format
- Large-capacity memory, one thousand kinds of pattern files can be stored into the memory.
- Support that import and export the pattern, parameters file etc.
- Support the type of wired / wireless network. It also supports remote monitoring with the 2G/3G/4G wireless modules.
- Record error and failure logs, and accurately alarm about failure.

Safety Precautions

1. Supply and environmental conditions

- Our machine only use the type of power source indicated on the product nameplate. More than 10% of the power fluctuations, must be equipped with power regulator
- Power line should be fixed and taken security measures according to the provisions, cannot bear any force.
- Device must be connected to ground, bad ground will cause electric shock and impact of safe and reliable operation of the product
- Direct input and output of the controller circuit for insulation testing is prohibited, or will directly cause damage to electrical equipment.
- Non-specialized technicians, please do not mobilize various origin sensor, otherwise the machine will not operate normally.
- Non-specialized technicians, please do not in the case of electricity to maintenance and demolition, otherwise it would be damage to the circuit board.
- The control system should be worked in clean, ventilated environments. Do not pile debris around the control box so as to facilitate cooling, and dust should be cleaned regularly
- The machine better temperature 15 °C ~ 28 °C.
- Humidity at 80% RH (non-condensing) within.

2. Operation guide

- For your personal and equipment safety, the machine must be reliable grounding
- The machine should be placed smooth and steady
- Risk of mechanical damage transmission parts, running in the hands or body parts do not close
- When error knitting, Please check whether the parameter settings and technological input is correct or not
- Sensor as the "eyes" of the machine, you need to be very careful care
- Turn off the power when the computer storage of data need to be a few seconds to open the power back again
- Eliminate the electrical equipment in damp, dust, corrosive gases, flammable and explosive gases workplace, otherwise it may cause an electric shock or fire.
- When the machine running, don't approach or touch any moving parts, or doing so may cause personal injury.
- When Faults occurred, it should be inspected and maintained by the professional and follow the specifications of the maintenance in this operation manual
- Jump back to the main screen when the machine adjustment or repair the machine, and the distance you fault detection alarm, so as not to cause danger to others negligence.

3. Repair and maintenance specifications

- Non-electrical professionals are not allowed to repair and test the electrical components, to avoid reducing the safety performance of equipment and to expand the malfunction and even cause personal injury and property damage.
- The electrical components inside the control machine box, we must ensure to conduct it in case of power failure, to ensure the safety of the operator
- Use the spare parts not provided by our company can easily cause fire, electric shock and serious damage.
- In order to ensure the safety of persons and property, please identify the product strictly in accordance with the specifications to replace the fuse
- The computer box cleared yarn crumbs, to turn off the power, the wire non pulling, best to brush with a vacuum cleaner sucked.
- Workshop for seven consecutive days does not start the power, every seven days for at least start the power one day, to maintain the best state of the electronic circuit.

The personal injuries or property damage caused by violation of operation manual, the company is free from any legal responsibility for.

Operation Manual

1. Starting Interface

1.1. A Factory Logo

- After power up, show the starting interface

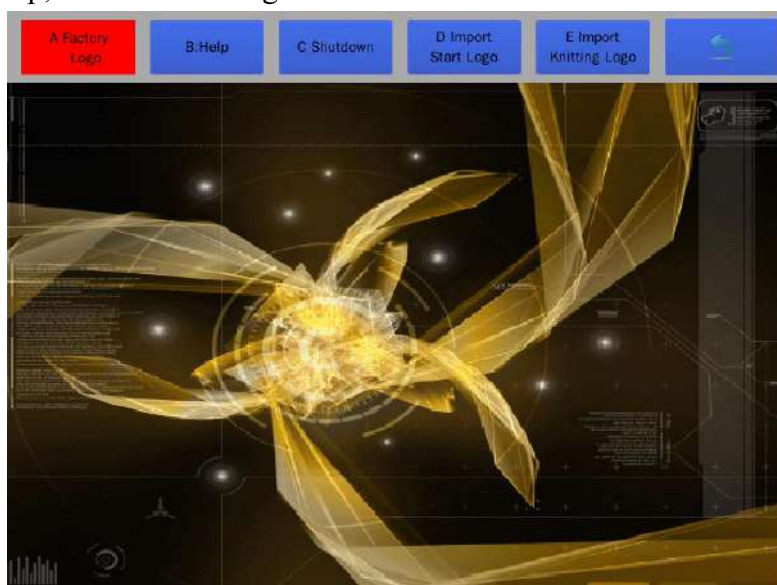

1.2. B Help

- View the shortcut keys for the system operation at any time.



1.3. C Shutdown

- Shutdown system of the computerized flat knitting machines.

1.4. D Import Start Logo

- Need to insert U disk, the starting logo is imported from the U disk into the memory.

1.5. E Import knitting Logo

- Need to insert U disk, the logo of the running interface is imported from U disk into the memory.

2. Running Interface

- Click the starting interface screen to enter the running interface. Return to the starting interface through clicking the display time position.

The screenshot shows the main control interface of the Raynen F4000 flat knitting machine. The interface is divided into several functional areas, each highlighted with a red dashed border and labeled on the left side:

- System function area:** Located at the top, it contains navigation icons for 'A Pattern Edit', 'B Work Param', 'C System Param', 'D Check', 'E File', and 'F Machine'. A digital clock displays '11:06' and the date '2015-09-30'.
- Knitting pattern information area:** This section displays parameters for two patterns. The left pattern has 'Density PAT' 0, '90 A Miss', and 'H Miss'. The right pattern has 'Density PAT' 0, '90 A Miss', and 'H Miss'. A 'Yarn' field is also present.
- Knitting parameters area:** This section contains various adjustable parameters such as 'MRoller', 'ARoller', 'Y-Park', 'Cycles', 'Start Row', 'Comb', 'ORoller', 'Sinkers', 'Rest', 'End Row', 'Speed', 'Yarn Sup', 'Start', 'Racking', and 'Rack Speed Normal'.
- Knitting basic information area:** This section shows 'Name' (4455), 'Set Piece' (9999), 'Total Rows' (100), 'Knit Time' (00:00:00), 'Single Time' (00:00:00), 'Needle Pos' (1961460), 'K Piece' (0), and 'K Rows' (1).
- Knitting running function area:** The bottom section features function keys: 'F1 Reset', 'F2 Locking' (with a lock icon), 'F3 Speed' (with a speed icon), 'Single Piece Stop' (with a stop icon), 'F5 Yarn Lift' (with an upward arrow icon), and 'F6 PgDn' (with a downward arrow icon).

 Note: Before knitting pattern, please confirm the knitting parameters and the working parameters

2.1. Running monitor screen display description

System function area	
A Pattern Edit	Enter the knitting parameters setting interface of the current pattern. See 3.1 Pattern Edit for details
B Working Parameters	See 3.2 working parameters for details
C System Parameters	See 3.3 System parameters for details
D Check	See 3.4 Check for details
E File	See 3.5 File for details
F Machine	See 3.6 Machine for details
System Time	Display the current time
Knitting pattern information area	
PAT	Current pattern row (PAT row No.) it's position corresponding with carriage real position.
Density	Display current density value (not contain density correction), its position corresponding with carriage real position.
Yarn feeder	Display current yarn feeder No. One system can pick two yarn at most. It's position corresponding with carriage real position. Left yarn is left yarn No, and right yarn is right yarn No.
A	Display A position information, left edit area display knitting action, right area display color code of PAT(0~F).
H	Display A position information, left edit area display knitting action, right area display color code of PAT(0~F).
Knitting parameters area	
Density	Set the density value of corresponding section which is used in current pattern. And the ahead density value can be set. Range: 1~640 Description: Color of the using density section can be set. And the using density section is displayed in the front, it is set in the working parameters interface.
Main Roller Auxiliary Roller Roller Open and close	Display the used main/auxiliary roller section of the current knitting row. The main/auxiliary roller speed can be set. And the stop torque of the main /auxiliary roller can be set. Range: -100~100
Comb	Display the used comb-tension section of the current knitting row. Set the tension value of comb. Range: 0~100
Speed	Display the used speed section of the current knitting row. The main motor speed value can be set. Set the speed value of current section. Range: 1~120
Yarn park position	Display the Carrier park position setting information. Range: 1~8

Sink	Set the current row’s section information of the sink. Set sink motor value, before use sink’s set value must ensure sink enable set in system parameters.
Starting needle	Set the actual position of the first needle on the first knitting row when the current pattern starts to knit. Description: If the starting needle has deviation when knit, please reset the totals in the system parameters.
Cycle	Display total times of current cycle. Description: Set the cycle times through clicking the “Cycles” button on the screen.
Knitting Basic Information Area	
File name	Display current knitting pattern name.
Needle position	Display carriage current position value of needle. Instruction: The value increase when it running to the right and decrease to the left.
Set pieces	Display the setting pieces of the current pattern. Range: 1~9999(piece) Instruction: Click into the set, when knitted pieces = setting pieces, machine will stop and prompts "pieces is finished"
Knitted pieces	Display current finished pieces of this machine Range: 0~9998
Total Rows	Display the total rows if the current pattern
Knitted Rows	Display the knitted rows of the current pattern Click the “K Rows” button to enter the “Skip Row” interface.
Knitting time	Display the total time from boot to the current.
Single time	Display the knitting previous piece time of the current pattern. It is the time of knitting one piece.

2.2. Function key F1~F6 Explanation on the running interface



- F1-F6 Function icon has two state, every icon has respective function. Click the “F6” can turn page on the first row.



- Carriage ready for reset back to zero position, the bar start or hand to push the carriage to move to the left limit and perform zero action.
- Reset process(After stating the bar):
 - 1) Carriage forward along the original direction reset speed to the limit point, encountered the reverse movement of the right limit until the left limit.
 - 2) When the carriage moving, if the bar stop and then start, the carriage will move to the left to the left limit.
 - 3) Selectors blade, Feeder electromagnet, cam electromagnet reset on the origin position.
 - 4) Density motor and sinker motor reset on the origin position.
 - 5) Reset as the speed of needle board move to the origin position.
 - 6) After reset, the machine is on the knitting state

⊘ **Warning:** Rocking action over one needle reset return to the origin, if the needle board is not in the position of the origin, and the front and back boards are fabric, you need to take off one side of the fabric, and not played needle.



- Open or close the roller
- Application: Set the roller Opening/closing of the torque or step motor
- The step motor roller: The bigger the value, the greater the open
- The torque motor roller: The bigger the value, the smaller the open
- Main/auxiliary roller adopts stepper motor roller mechanism: Control opening and close.

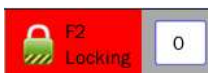

- Cycle knitting 1 and 2 lines. The locking times can be input at back of the text box.
- When the locking time is 0, select the Locking, the locking need to be canceled manually until the fabric into the roller.
- When the locking time is not 0, select the Locking, cycle times of the locking is finished, the locking will be automatically cancelled

Explanations:

- 1) When the pattern is in the first row can be implementation of the action.
- 2) When the comb is valid can't perform the action.
- 3) Need to stop perform.



- System alarm valid and invalid switching.

Explanations:

- 1) Invalid object for the alarm antenna sets broken yarn, edge yarn, knot alarm, other alarm is still in force.
- 2) When it alarm, the carriage stop, stop bits or click bar steering alarm confirmation window to clear the alarm information on the touch screen, normal knitting again.
- 3) Perform Without stopping the machine.



- Carriage run high, low speed, and can switch.

Explanations:

- 1) This function is valid only handle high-speed, otherwise handle low-speed running.
- 2) Low speed to set operating parameters in low-speed ceiling "of the main motor speed run.
- 3) High speed as the “speed” section of knit parameter running.
- 4) High speed when the highest rate that does not exceed the set values of the operating parameters in the main high-speed motor upper limit.
- 5) No parking, you can switch directly.
- 6) Commencement of the next line performs after speed switching.



- When the total width of the knitting pattern is small, the number of used carriers is less. To improve the knitting efficiency, the pattern can be knitted multi piece at same time on the machine.
- Please Reasonably set according to the total needles of machine, the total width of pattern, and the number of carrier.



- The single piece stop and the appoint row stop can be set.



- Single Piece Stop: Use the shortcuts key (F4), or click the “F4 Single Piece Stop” area on the screen.
- Appoint Row Stop: Input the PAT row in the “Appoint Row” text, use F1 key to insert. If Delete appoint row, the cursor need to select the row numbers. “F3 Empty” is delete all appoint rows.



- Open or Close the fluorescent lamp in the flat knitting machine.



- Yarn Up and Down switch. Switch all feeds of current knitting line.

Explanations:

- 1) Can't turn on feeder raise status, it has to drop and then run.
- 2) Need to stop perform.



- Test the left or right yarn supplier





➤ Turn the page

3. System Function Interface

3.1. Pattern Edit

3.1.1. Program Edit

Annotations:

- PAT rows of back
- Back Selector information
- The yarn feeder in the current knitting
- PAT rows of front
- Front Selector information
- Knitting parameters
- CNT the line number/total

F4 Carrier Bundle:

➤ Click on the button , Or use shortcuts key F4, show the following interface.

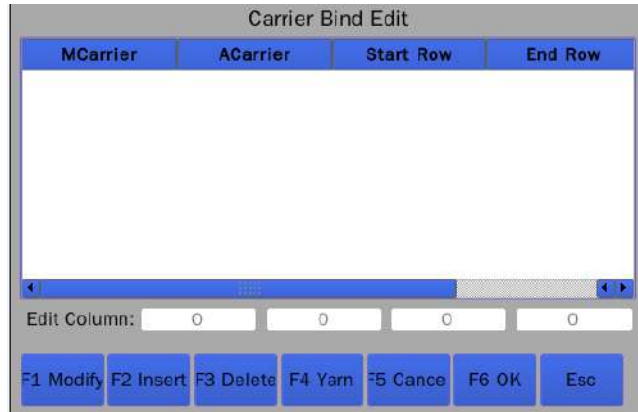

- **Descriptions:** the main carrier is the used carrier of the current pattern, auxiliary carrier is the added carrier, the starting row and end row is a certain period of the pattern (Don't need to pay attention to the odd and even row). When pattern is knitted into the start row, if the main carrier is used, the auxiliary carrier will be added automatically.

3.1.2.  **Pattern Edit**

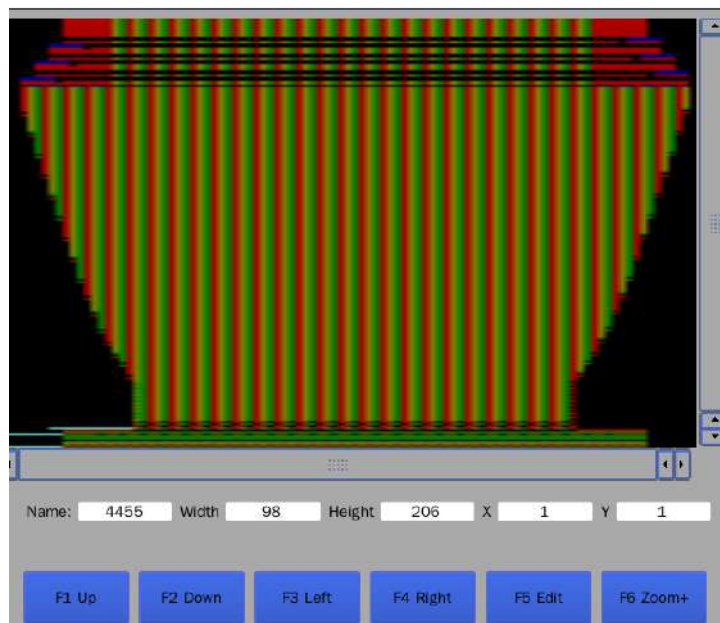

Descriptions:

- 1) Click the “Zoom +/-” button to move cursor, select the pattern code which needs to be modified. Click the pattern editor window to edit pattern.
- 2) Press “UP, DOWN, LEFT, RIGHT” key to move the cursor, positioning the pattern code needed to be modified, click the “Edit” window for editing pattern
- 3) Pattern code are the pattern data in the first pattern mapping, indicate in 0 ~ F.

3.1.3.



Carriers swap/replace



Carriers swap/replace introduction:

- 1) Input the origin and replaced carrier number
- 2) Click the “F3 Replace” button to finish the carriers replace. The Shortcut key is F3
- 3) Click the “F4 Swith” button to finish the carriers swap. The Shortcut key is F4.

Note: 1) Feeders after replacing are same side. Two feeders of different side (Left and Right) can't be replaced.
 2) The yarn feeder replace is effective to the current pattern.
 3) Press the F5 key after swap, or the feeders aren't change after power down and chose another pattern.

3.1.4.



Cycle

	Start Row	End Row	Times
1	0	0	0
2	0	0	0
3	0	0	0
4	0	0	0
5	0	0	0
6	0	0	0
7	0	0	0
8	0	0	0
9	0	0	0
10	0	0	0

Total Rows:208
Page:1

F1 F2 PgUp F3 PgDn F4 F5 F6 Save

Cycle introduction:

- 1) The start row is the odd row, the end row is the even row. And the end row must be greater than the start row.
- 2) There is not the cycle nesting function.
- 3) In turn perform the cycle function according to the serial number.
- 4) When the cycle time is set to zero, the cycle of the corresponding row will be cancelled.
- 5) After completing set, when return the “whether save” tip will be display. Need to select OK, otherwise the set will not save after power down or change pattern.

3.2. Working parameters

3.2.1. Normal Parameters

M Motor Hnadle H Speed Limit	<input type="text" value="98"/>	Auto Reset Pieces	<input type="text" value="10"/>
M Motor Hnadle L Speed Limit	<input type="text" value="40"/>	Back Sinker Reset	<input type="text" value="0"/>
M Motor Hnadle Low Speed	<input type="text" value="20"/>	Front Sinker Reset	<input type="text" value="0"/>
M Motor Hnadle Reset Speed	<input type="text" value="15"/>	Carrier Drop Advance Value	<input type="text" value="18"/>
F Needle Bed Crush Sensitivity	<input type="text" value="70"/>	Screen Brightness	<input type="text" value="50"/>
B Needle Bed Crush Sensitivity	<input type="text" value="70"/>	Buzzer Alarm Time	<input type="text" value="0"/>
MRoller Act Mode	<input type="text" value="Continuous"/>	Rotate Troque Space(N)	<input type="text" value="5"/>
MRoller Stop Toque	<input type="text" value="5"/>	Knot L-Speed Rows	<input type="text" value="3"/>
ARoller Stop Toque	<input type="text" value="5"/>	ARoller Enable	<input type="text" value="No"/>
Yarn Supply Enable	<input type="text" value="Off"/>	Shield Buzzer	<input type="text" value="NO"/>
Screensaver(Time)	<input type="text" value="0"/>		
Used Sections Ahead	<input type="text" value="Yes"/>		

F1 Save Param	F2 Restore Param	F3 Initialize	F4	F5	F6
-------------------------	----------------------------	-------------------------	-----------	-----------	-----------

Working parameters introduction:

Main Motor Handle High Speed Limit	In status of knitting, set the highest percentage between the high-speed mode of the main motor and the full speed ◆ Range: 60~120 ◆ Step: Click the text box value, the pop-up keypad to enter a value, click OK
Main Motor Handle Low Speed Limit	In status of knitting, set the highest percentage between the low-speed mode of the main motor and the full speed ◆ Range: 20~60 ◆ Step: Click the text box value, the pop-up keypad to enter a value, click OK
Main Motor Handle Low speed	Main motor handle low speed – In status of handle low speed, set the knitting speed of the main motor and the full speed ◆ Range: 5~30 ◆ Step: Click the text box value, the pop-up keypad to enter a value, click OK
Main Motor Handle Reset speed	In status of original reset, set the knitting carriage speed between the full speed ◆ Range: 5~15 ◆ Step: Click the text box value, the pop-up keypad to enter a value, click OK
Front/Back strike Sensitivity	Set the sensor sensitivity when the front or back needle board is strike. The greater the value, the more sensitive. 0: close the sensitivity ◆ Range: 0~100 ◆ Step: Click the text box value, the pop-up keypad to enter a value, click OK
Main roller act mode	Set main roller act mode ◆ Range:"0" - Double side rolling: When the carriage is at both sides of the margins, the main roller rolling

	<p>“1” - Continuous rolling: When the carriage running, the main roller continuous rolling</p> <ul style="list-style-type: none"> ◆ Step: Click the text box value, the pop-up keypad to enter a value, click OK
Marin roller stop torque	<p>Set the main roller keeping torque after stopping machine</p> <ul style="list-style-type: none"> ◆ Range:0~50 ◆ Step: Click the text box value, the pop-up keypad to enter a value, click OK
Auxiliary roller stop torque	<p>Set the auxiliary roller keeping torque after stopping machine</p> <ul style="list-style-type: none"> ◆ Range:0~50 ◆ Step: Click the text box value, the pop-up keypad to enter a value, click OK
Yarn Supplier enable	<p>Set the auxiliary yarn feeder opening and closing status</p> <ul style="list-style-type: none"> ◆ Range:0 is all close; 1 is open left; 2 is open right; 3 is all open ◆ Step: Click the text box value, the pop-up keypad to enter a value, click OK
Screen-Saver Time (minute)	<p>Set the still time when the screen protective program takes effect (no operating time) in no operation.</p> <ul style="list-style-type: none"> ◆ Range: 0~60. Zero is that the screen-saver function is not working. ◆ Step: Click the text box value, the pop-up keypad to enter a value, click OK
Used Section Ahead	<p>Set whether used section arrangement ahead</p> <ul style="list-style-type: none"> ◆ Range: 0 is NO; 1 is Yes ◆ Step: Click the text box value, the pop-up keypad to enter a value, click OK
Automatic reset pieces	<p>After knitting the setting value, the total pieces return to zero automatically, and enter into the original position to reset, After resetting, the machine begin to knit automatically</p> <ul style="list-style-type: none"> ◆ Range:0~100 ◆ Step: Click the text box value, the pop-up keypad to enter a value, click OK
Back Sinker Reset	<p>Set the distance value (pulse) between the back sinker stepper control motor and sinker zero probe after the carriage original position reset</p> <ul style="list-style-type: none"> ◆ Range:0~1000 ◆ Step: Click the text box value, the pop-up keypad to enter a value, click OK
Front Sinker Reset	<p>Set the distance value (pulse) between the front sinker stepper control motor and sinker zero probe after the carriage return to zero position reset</p> <ul style="list-style-type: none"> ◆ Range:0~1000 ◆ Step: Click the text box value, the pop-up keypad to enter a value, click OK
Carrier Drop Advance value	<p>Set the yarn feeder fall ahead of the volume (needle) when knitting</p> <ul style="list-style-type: none"> ◆ Range: 0~42 ◆ Step: Click the text box value, the pop-up keypad to enter a value, click OK
Screen Brightness (%)	<p>Set the percentage of screen brightness</p> <ul style="list-style-type: none"> ◆ Range:3~1000 ◆ Step: Click the text box value, the pop-up keypad to enter a value, click OK
Buzzer Alarm Time	<p>Set the buzzer alarm time. The buzzer alarm time when the alarm is displayed on the interface. Stop the buzzer after arrival set time.</p> <ul style="list-style-type: none"> ◆ Range:0~60 ◆ Step: Click the text box value, the pop-up keypad to enter a value, click OK
Rotary Torque Space	<p>Set the carriage at both ends of the knitting patterns for fine-tuning the torque when</p>

(N)	the (needle) <ul style="list-style-type: none"> ◆ Range:0~50 ◆ Step: Click the text box value, the pop-up keypad to enter a value, click OK
Knot Low Speed Rows	Set the knitting rows of low speed when alarm for the little knots, to prevent that yarn is break for fast speed <ul style="list-style-type: none"> ◆ Range:0~10 ◆ Step: Click the text box value, the pop-up keypad to enter a value, click OK
Auxiliary roller enable	Whether is the auxiliary roller valid? <ul style="list-style-type: none"> ◆ Range: “Yes” is valid; “No” is invalid. ◆ Step: Click the text box value, the pop-up keypad to enter a value, click OK
Shield Buzzer	Set whether the buzzer alarm is effective. <ul style="list-style-type: none"> ◆ Range: “1” is “Yes”; “0” is “NO”. ◆ Step: Click the text box value, the pop-up keypad to enter a value, click OK

- **F1 Save Parameters:** Click the “Save Param”, the modified Parameters will be saved to the memory.
- **F2 Restore Parameters:** Click “Restore Param”, Recently saved parameters will be called from the memory.
- **F3 Initialized:** Click the “Initialized”, working parameters restore to the factory settings

3.2.2. B Yarn Speed Correction Yarn Speed Correction

Nomal Yarn Speed Correction								
	[Yarn1]		[Yarn2]		[Yarn3]		[Yarn4]	
Speed	L<<-R	L->>R	L<<-R	L->>R	L<<-R	L->>R	L<<-R	L->>R
1~5	1.00	0.00	0.00	0.00	0.00	0.00	0.00	0.00
6~10	2.00	0.00	0.00	0.00	0.00	0.00	0.00	0.00
11~15	3.00	0.00	0.00	0.00	0.00	0.00	0.00	0.00
16~20	4.00	0.00	0.00	0.00	0.00	0.00	0.00	0.00
21~25	5.00	0.00	0.00	0.00	0.00	0.00	0.00	0.00
26~30	6.00	0.00	0.00	0.00	0.00	0.00	0.00	0.00
31~35	7.00	0.00	0.00	0.00	0.00	0.00	0.00	0.00
36~40	8.00	0.00	0.00	0.00	0.00	0.00	0.00	0.00

Intarisia Page:1/8

F1 Switch	F2 Yarn PgUp	F3 Yarn PgDn	F4 Speed PgUp	F5 Speed PgDn	F6 Copy
--------------	-----------------	-----------------	------------------	------------------	------------

- **Carrier Speed Correction Descriptions:** Set the advance needles which of normal carrier is lefted by electromagnet on the current speed, it is used in conjunction with the “yarn stop position”.
- **F1 Switch:** Swith to the interface of intarsia carroer speed correction. Setting mode is same as normal carroer speed correction
- **F2、 F3 Carrier PgUp/PgDn:** Four carriers are displaid on the current page, need page up or down to set more carriers.
- **F4、 F5 Speed PgUp/PgDn:** Eight speed sections are displaid on the current page, need page up or down to set orther speed section (the maxium speed is 120).

3.3. System Parameters

3.3.1. System parameters

- System parameters affect the completely machine performance, which are set by the completely machine mechanical parameters. This parameter is tested by the computerized flat knitting machine manufacturers, and confirmed when ex-factory. Users generally do not need to modify. If need modified, it must be carried out by professionals. To enter into system parameter settings, you should enter into the password.



Note: For the new machine system parameters, set the order as follows: ① needle number per inch, ② Needle bed total needle number ③ Needle bed total pulses number

Function Descriptions:

- **F1 Parameters Save:** Click the “Param Save”, the modified Parameters will be saved to the memory.
- **F2 Parameters Restore:** Click “Restore Param”, Recently saved parameters will be called from the memory.
- **F3 Initialized:** Click the “Initialized”, system parameters restore to the factory settings
- **F4 Touch Screen:** Click “F4 Touch Screen”, Click the screen to finish correcting according to the prompt.
- **F5 Automatically Write:** when the carriage stop, click “F5 Auto write”, the needle position of the carriage will be filled in the selected text.
- **F6 More Parameters and Normal Parameters:** Switch the normal or more parameters page.
- **Yarn Control:** when set the yarn feeder left or right zero position, control any carrier electromagnet to fall up or down.

Normal parameters Descriptions:

- **Needles Per Inch (N)**
 - Set the needle number per one inch on the needle bed.
 - Range: 2-16
 - Explanation: After setting must restart the machine immediately, so that the back of the total pulse.
 - **Key:** The arrow keys move the cursor to the gray text box. Digital Select input value and press the Enter key.
 - **Touch:** Click the text box value, the pop-up keypad to enter a value, click OK.
- **Total needles (N)**
 - Set-sided needle bed needle number. It is the maximum knitting needles.
 - range: 1~1200
 - **Key:** Arrow keys to move the cursor to the "Total needles" text box, press F5 will automatically write this needle position
 - **Touch:** Click "Total needles" text box (Cancel the pop-up keypad), Click the “F5 Auto Write” area to automatically write the current needle position.
- **Needle Zero Position**
 - Machine original position
 - range: 1~9999
 - Automatic steps:
 - 1) Complete the belt tooth moment correction value after reset

- 2) Moving machine head to the left side of the needle bed, the left side or cam of the carriage corresponds to the left inner edge of the first needle groove.
 - ☞ **Key:** Arrow keys to move the cursor to the "needle zero position" text box, press F5 will automatically write this needle
 - ☞ **Touch:** Click "needle zero position" text box (Cancel the pop-up keypad), Click the “F5 Auto Write” area to automatically write the current needle position.
 - Manual steps:
 - ☞ **Key:** The arrow keys move the cursor to the gray text box. Digital Select input value and press the Enter key.
 - ☞ **Touch:** Click the text box value, the pop-up keypad to enter a value, click OK
 - Needle zero value must be positive, when the needle zero sensor adjust the position, you must reset this value.
- ★ The left side or cam of the carriage corresponds to the left inner edge of the first needle groove (According to the actual carriage size).

➤ Syn Gear Correction

- Set the synchronous gear when carriage is knitting (the value of the pulse in the total number of stitches)
 - Range: 1~999999
 - Automatic steps:
 - 1) Hand move machine head to the left side of the needle bed, the left side of the machine head edge at the needle bed first needle.
 - ☞ **Key:** Move the cursor to the “belt tooth Moment correction value” text box, Press 1 will be automatically written to the starting value.
 - 2) Hand move machine head to the right side of the needle bed, the left side of the machine head edge at the last needle of the needle bed.
 - ☞ **Key:** Press 2 will be automatically written to the ending value.
 - 3) Compute and confirm total pulse value.
 - ☞ **Key:** Press 3 will automatically compute the result value, choose confirm will automatically write total pulse value.
 - Manual steps:
 - ☞ **Key:** Move the cursor to the corresponding number area, until the digital select input value and press the Enter key
- ★Special note: If the selector size measurement is start from the left side of the carriage, the measurements of the total pules and needle zero position are to the left edge alignment. If the selector size measurement is start from the left cam of the carriage, the measurements of the total pules and needle zero position are to the left cam alignment.

➤ **Selector RF correction/ Selector RB correction**

- Setting needle selector right direction and front/back bed correction value
- Range: -14--14
- Description:
 - 1) This parameter is setting the needle selector shaving heads right running and front /back knitting advance\hysteresis, the entry into force of the right running and front /back knitting needle selector.
 - 2) When carriage direction is right, the value is positive number, needle selector head work ahead of time, the value is negative number, needle selector head behind work;
- **Key:** arrow keys move the cursor to the gray text box, until the Digital Select input value and press the Enter key
- **Touch:** Click on the text box value, and pop-up keypad to enter a value, click OK.

➤ **Selector LF correction/ Selector LB correction**

- Setting needle selector left direction and front/back bed correction value
- Range: -14--14
- Description:
 - 1) This parameter is setting the needle selector shaving heads left running and front /back knitting advance\hysteresis, the entry into force of the left running and front /back knitting needle selector.
 - 2) When carriage direction is left, the value is positive number, needle selector head behind work, the value is negative number, needle selector head work ahead of time;
- **Key:** arrow keys move the cursor to the gray text box, until the Digital Select input value and press the Enter key
- **Touch:** Click on the text box value, and pop-up keypad to enter a value, click OK.

➤ **Y Park Position correction (needle)**

- You can set the position of the Yarn Feeder the electromagnets filed or lag.
- Range: 0 ~100mm
- **Key:** arrow keys move the cursor to the gray text box, until the Digital Select input value and press the Enter key
- **Touch:** Click on the text box value, and pop-up keypad to enter a value, click OK.

➤ **Rec Density Correction**

- Set the correction value of receiver density.
- **Key:** arrow keys move the cursor to the gray text box, until the Digital Select input value and press the Enter key
- **Touch:** Click on the text box value, and pop-up keypad to enter a value, click OK.

➤ **Carriage L Limit**

- Machine head left limit distance from the origin (needles)
- range: -99999 ~ 0 (**this value is generally negative**)
- Steps: Hand Move machine head to the left, the nose the stopper sheet iron close to the left limit sensing probe, when the probe indicator just lit, stop move machine head (Indicator light of the probe are lit, the signal detection state is "0").
- **Key:** Arrow keys to move the cursor to the "Carriage L Limit" text box, press F5 will automatically write this needle position
- **Touch:** Click "Carriage L Limit" text box (Cancel the pop-up keypad), Click the “F5 Auto Write” area to automatically write the current needle position.

➤ **Carriage R Limit**

- Machine head right limit distance from the origin (needles),
- range: 0 to 99999 (**Note: this value is positive integer**)
- Steps: Hand Move machine head to the right, the nose the stopper sheet iron close to the right limit sensing probe, when the probe indicator just lit, stop move machine head (Indicator light of the probe are lit, the signal detection state is "0").
- **Key:** Arrow keys to move the cursor to the "Carriage R Limit" text box, press F5 will automatically write this needle position
- **Touch:** Click "Carriage R Limit" text box (Cancel the pop-up keypad), Click the “F5 Auto Write” area to automatically write the current needle position.

★ **Carriage left/right limited sensing probe is used to protect carriage which is beyond knitting range non-normally in process of knitting (Indicator light went out, the signal detection state is "1").**

➤ **System L Yarn R Zero Position/System R Yarn R Zero Position**

- Set the distance value (needle number) of the left/right systems yarn feeder right running and the origin position, the range of 1 to 9999
- Steps:
 - 1) Take one yarn feeder, align the yarn feeder feeding hole center to the first needle groove center of the front needle bed;
 - 2) Move the carriage by hand, align the right side of the yarn carrier change cores of the left/right system to the right side of the yarn carrier stopper
 - 3) Click the text box, the current displayed needle number value can be written automatically
- **Key:** Arrow keys to move the cursor to the "System L/R Yarn R Zero Position" text box, press F5 will automatically write this needle position
- **Touch:** Click "System L/R Yarn R Zero Position" text box (Cancel the pop-up keypad),

Click the “F5 Auto Write” area to automatically write the current needle position.

➤ **System L Yarn L Zero Position/System R Yarn L Zero Position**

- Set the distance value (needle number) of the left/right systems yarn feeder left running and the origin position, the range of 1 to 9999
- Step:
 - 1) Take one yarn feeder, align the yarn feeder feeding hole center to the first needle groove center of the front needle bed;
 - 2) Move the carriage by hand, align the left side of the yarn carrier change cores of the left/right system to the left side of the yarn carrier stopper
 - 3) Click the text box, the current displayed needle number value can be written automatically
- **Key:** Arrow keys to move the cursor to the "System L/R Yarn L Zero Position" text box, press F5 will automatically write this needle position
- **Touch:** Click "System L/R Yarn L Zero Position" text box (Cancel the pop-up keypad), Click the “F5 Auto Write” area to automatically write the current needle position.

➤ **Racking Speed Set (%)**

- Set the speed of knitting high-speed racking.
- The range: 1~100
- **Key:** Move the cursor to the gray text box, until the Digital Select input value and press the Enter key
- **Touch:** Click on the text box value, and pop-up keypad to enter a value, click OK.

➤ **Racking Medium Speed Set (%)**

- Set the medium speed of knitting high-speed racking.
- The range: 1~100
- **Key:** Arrow keys move the cursor to the gray text box, until the Digital Select input value and press the Enter key
- **Touch:** Click on the text box value, and pop-up keypad to enter a value, click OK.

➤ **Racking Low Speed Set (%)**

- Set the low speed of knitting high-speed racking.
- The range: 1~100
- **Key:** Arrow keys move the cursor to the gray text box, until the Digital Select input value and press the Enter key
- **Touch:** Click on the text box value, and pop-up keypad to enter a value, click OK.

➤ **Sinker Enable**

- Setting sinker motor working status
- Range: “0” is that sinker and corresponding parameters is invalid; “1” is that sinker and corresponding parameters is effective.
- **Key:** Arrow keys move the cursor to the gray text box, until the Digital Select input value and press the Enter key
- **Touch:** Click on the text box value, and pop-up keypad to enter a value, click OK.
- **This parameter applies to the sinker mechanism which is controlled by step motor.**

➤ **Selector Energy Saving**

- To set needle selector is energy conservation (ice. the re-election of the work)
- Range: “0” is invalid; “1” is valid.
- **Key:** Arrow keys move the cursor to the gray text box, until the Digital Select input value and press the Enter key
- **Touch:** Click on the text box value, and pop-up keypad to enter a value, click OK.

➤ **System Lock**

- Set whether lock the working system.
- Range: 0-Lock system; 1-Unlock system.
- **Key:** Arrow keys move the cursor to the gray text box, until the Digital Select input value and press the Enter key
- **Touch:** Click on the text box value, and pop-up keypad to enter a value, click OK.

System Parameters (F6 More Param):



➤ **Rocking Space correction**

- Set gap correction because racking ball screw reciprocating change direction.
- Range: 0 ~ the pulse of half needle racking
- **Key:** Arrow keys move the cursor to the gray text box, until the Digital Select input value and press the Enter key
- **Touch:** Click on the text box value, and pop-up keypad to enter a value, click OK.

➤ **Yarn supplier Start delay time**

- Set the time which of Yarn supplier start is earlier than the start time after starting
- Range: 0~10000 (ms)
- **Key:** Arrow keys move the cursor to the gray text box, until the Digital Select input value and press the Enter key
- **Touch:** Click on the text box value, and pop-up keypad to enter a value, click OK.

➤ **Yarn supplier Parking delay time**

- Set the time of yarn supplier continue run after stopping,
- range: 0 ~ 10000 (ms)
- **Key:** Arrow keys move the cursor to the gray text box, until the Digital Select input value and press the Enter key
- **Touch:** Click on the text box value, and pop-up keypad to enter a value, click OK.

➤ **System 1/2_L/R density position correction (mm)**

- Fine tune the machine position of the left/right density cam in system 1/2.
- **Key:** Arrow keys move the cursor to the gray text box, until the Digital Select input value and press the Enter key
- **Touch:** Click on the text box value, and pop-up keypad to enter a value, click OK.

➤ **Variable Density Enable**

- Open or close the variable density function of the system. If open, pattern has set variable density.
- Range: “0” is the invalid; “1” is effective.
- **Key:** Arrow keys move the cursor to the gray text box, until the Digital Select input value and press the Enter key
- **Touch:** Click on the text box value, and pop-up keypad to enter a value, click OK.

➤ **Second Density Value**

- Set the value of the first action when second density is used, if the value is zero, second density function is closed.

- Range: 0~300
 - **Key:** Arrow keys move the cursor to the gray text box, until the Digital Select input value and press the Enter key
 - **Touch:** Click on the text box value, and pop-up keypad to enter a value, click OK.
- **Second density in speed correction**
- When the second action of second density is executed, set the advance action distance before the cam come in the knitting area. If the value is positive number, it closes to the knitting area; if the value is negative number, it is far from knitting area.
 - Range: -50~50mm
 - **Key:** Arrow keys move the cursor to the gray text box, until the Digital Select input value and press the Enter key
 - **Touch:** Click on the text box value, and pop-up keypad to enter a value, click OK.
- **Second density out speed correction**
- When the second action of second density is executed, set the advance action distance before the cam come out the knitting area. If the value is positive number, it closes to the knitting area; if the value is negative number, it is far from knitting area.
 - Range: -50~50 mm
 - **Key:** Arrow keys move the cursor to the gray text box, until the Digital Select input value and press the Enter key
 - **Touch:** Click on the text box value, and pop-up keypad to enter a value, click OK.
- **Ahead Density Enable**
- Set whether ahead density is effective.
 - Range: 0~NO; 1~YES
 - **Key:** Arrow keys move the cursor to the gray text box, until the Digital Select input value and press the Enter key
 - **Touch:** Click on the text box value, and pop-up keypad to enter a value, click OK.
- **Density Reset Add Value**
- Set Additional rotational value when the density motor reset in the process of changing carriage direction.
 - Range: 0-10, the higher the value, the more turning.
 - **Key:** Arrow keys move the cursor to the gray text box, until the Digital Select input value and press the Enter key
 - **Touch:** Click on the text box value, and pop-up keypad to enter a value, click OK.

➤ **Density Reset Checking Enable**

- Set whether check the reset status of ahead density motor when carriage direction is changed.
- “0” is invalid, “1” is effective
- **Key:** Arrow keys move the cursor to the gray text box, until the Digital Select input value and press the Enter key
- **Touch:** Click on the text box value, and pop-up keypad to enter a value, click OK.

➤ **Density Alarm Allow Error Value**

- Set the error value when check density resetting. If error is within the set error value, density reset alarm is pointed out. This value applies to all density motor.
- Range: 0~20. The smaller the value, the more sensitive.
- **Key:** Arrow keys move the cursor to the gray text box, until the Digital Select input value and press the Enter key
- **Touch:** Click on the text box value, and pop-up keypad to enter a value, click OK.

➤ **Density Motor Has Encode**

- Set whether density motors have encode in machine, the normal machine type is not encode.
- “0” is NO, “1” is YES
- **Key:** Arrow keys move the cursor to the gray text box, until the Digital Select input value and press the Enter key
- **Touch:** Click on the text box value, and pop-up keypad to enter a value, click OK.

➤ **Variable Density Speed**

- When open the variable density function, whether the carriage speed need to be limited.
- Range: 0~120
- **Key:** Arrow keys move the cursor to the gray text box, until the Digital Select input value and press the Enter key
- **Touch:** Click on the text box value, and pop-up keypad to enter a value, click OK.

➤ **Intarsia Max Speed**

- Set the maximum speed of intarsia carriage
- **Key:** Arrow keys move the cursor to the gray text box, until the Digital Select input value and press the Enter key
- **Touch:** Click on the text box value, and pop-up keypad to enter a value, click OK.

3.3.2. **B Racking** Racking

00	0					R0*	0
L1	0	R1	0	L1*	0	R1*	0
L2	0	R2	0	L2*	0	R2*	0
L3	0	R3	0	L3*	0	R3*	0
L4	0	R4	0	L4*	0	R4*	0
L5	0	R5	0	L5*	0	R5*	0
L6	0	R6	0	L6*	0	R6*	0
L7	0	R7	0	L7*	0	R7*	0
L8	0	R8	0	L8*	0	R8*	0

Range:-85~85 Page:1/2

F1 Copy F2 PgUp F3 PgDn F4 F5 F6

Racking position description:

- 1) Inputting value is racking pulse. The Range: -85~85
- 2) Confirm the action according to the inputting value of the racking direction and needles and amending. Check it?
- 3)  The needle-bed position is resetting rack.
- 4) “L” is left rack, “R” is right rack, the value is needles, “*” is that needle face needle (It is the position of needle face tooth that there has no “*”))
- 5) When copy something, the cursor need to be in the right amending position, and paste a single column (not all).
- 6) The Correction value is working in racking knitting, and not working in transferring racking.

Key:

- 1) Move the cursor to the corresponding textbox through the direction key, and press “OK” after finished the digital input.
- 2) Press the F1 to copy, other key is not working.

Touch:

- 1) Click the digital area of the textbox. Then input the value with pop-up keyboard and click “OK”
- 2) Click the area of “F1 Copy” to copy.

★ In process of the new machine installation and commissioning, all racking needle position must be completely tested. Error value of every needle position is best to be less than or equal to 0.02 mm.

3.3.3. C Transfer Racking Transfer Racking

				0	-	+					
				0.	-20	0	0				
L1	5	0	0	R1	-20	0	0				
L2	-20	0	0	R2	-20	0	0				
L3	-20	0	0	R3	-20	0	0				
L4	-20	0	0	R4	-20	0	0				
L5	-20	0	0	R5	-20	0	0				
L6	-20	0	0	R6	-20	0	0				
L7	-20	0	0	R7	-20	0	0				
L8	-20	0	0	R8	-20	0	0				
Range:-85~85				Page:1/2							
F1 Copy			F2 PgUp			F3 PgDn			F4		
F5			F6								

Transfer racking description:

- 1) Inputting value is racking pulse. The Range: -85~85
- 2) Confirm the action according to the inputting value of the racking direction and needles and amending. Check it and transferring is smooth?
- 3) The Correction value is working in transferring racking, and not working in racking knitting.
- 4) “L” is left rack. “R” is right rack. The value is needle. The racking position is that needle face needle.
- 5) When copy something, the cursor need to be in the right amending position, and paste a single column (not all).

Key:

- 1) Move the cursor to the corresponding textbox through the direction key, and press “OK” after finished the digital input.
- 2) Press the F1 to copy, other key is not working.

Touch:

- 1) Click the digital area of the textbox. Then input the value with pop-up keyboard and click “OK”
- 2) Click the area of “F1 Copy” to copy.

3.3.4. D Density Correction Density Correction

System	Single1	Single2	Double1	Double2
L System	0	-300	0	0
R System	0	0	0	-300
B	0	0	0	0
F	0	0	0	0

Function keys: F1 Variable Dumu, F2, F3, F4, F5, F6

Density correction description:

- 1) Density correction position is a one-to-one correspondence with the dual system machine head-density
- 2) Single-sided in addition to No.3, 10 color code outside organizations drawn graphics, Sided refers organizational pattern drawn with the No. 3, No. 10.
- 3) Knitting -density project implementation torque: The -density number of segments set value + -density compensation value.
- 4) Run interface display the stitch segment values , machine head test interface to display the actual -density value.

Key: Move the cursor to the corresponding textbox through the direction key, and press “OK” after finished the digital input.

Touch: Click the digital area of the textbox. Then input the value with pop-up keyboard and click “OK”.

3.3.5. E Double Density Double Density

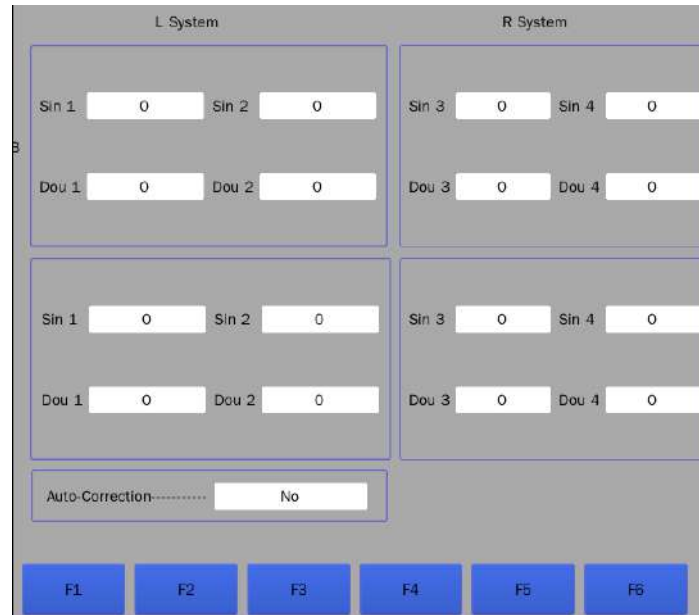

Double density description:

- 1) It is working when the double system are all used to knit. That one system knit is not working.
- 2) Because of knitting with double system, the density is uneven for that the roller has different tension on two systems. Amend every density motor according to this state.
- 3) The density amending value and the position of the density motor is corresponding.
- 4) The range of amending is -100~100. When the double density amending is working, the actual density value = the value after amending density + the double density amending value (The actual density value can't be negative)
- 5) The double density amending value has not affect to set the density amending value

Key: Move the cursor to the corresponding textbox through the direction key, and press “OK” after finished the digital input.

Touch: Click the digital area of the textbox. Then input the value with pop-up keyboard and click “OK”.

3.3.6. F Comb Comb

Comb parameters:

Left Parking Position	0	1~100 Pin Pull	1
Right Parking Position	700	101~200 Pin Pull	5
Cut Act Times	1	201~300 Pin Pull	10
Comb Stop Torque(%)	20	301~400 Pin Pull	10
L-Clip Enable	Yes	401~500 Pin Pull	10
R-Clip Enabled	Yes	More Than 500 Pin Pull	20
Comb Enable	Yes	L-Clip2 Park	0
Comb Delay Release Pulse	100	L-Clip1 Park	0
Comb Hook Failed Row	25	R-Clip1 Park	0
L-Clip2 Highest Pulse	0	R-Clip2 Park	0
L-Clip1 Highest Pulse	0	Cut Over Zero Pulse	200
R-Clip1 Highest Pulse	0	Comb Brake Rows	2
R-Clip2 Highest Pulse	0	Test Menu Modify Enable	No

F1 F2 F3 F4 F5 F6 More Param

➤ Left Parking position (Needle)

- The left carrier parking position after yarn out. Input the number of reading the needles when the head is moved to the position from the left edge.
- Range: Left limit position ~ Needle zero position
- Description: if the inputting value is too less to hit the left limit position and alarm that the head is out of left limit position on yarn in/out.

➤ Right Parking position (Needle)

- The right carrier parking position after yarn out. Input the number of reading the needles when the head is moved to the position from the right edge.
- Range: Total pulses ~ Right limit position
- Description: if the inputting value is too less to hit the right limit position and alarm that the head is out of right limit position on yarn in/out.

➤ Cut Act Times

- The times of scissors cut yarn (The coarse yarn can't be cut off if cut one time, the number need be set)
- Range: 1~5

➤ Comb stop torque (%)

- When the non-brake comb mode is used, maintain the tension value after stopping machine

- Range: 0~100

- **Left/Right Clip Enable**
 - The left/right clip effective, the machine carriage execution the left/right yarn into action, otherwise the machine head only in the outer yarn knitting area
 - Range: 0 invalid, 1 valid

- **Comb Enable**
 - After comb effective, comb has the action of hooking yarn, otherwise comb does not move
 - Range: 0 invalid, 1 valid

- **Comb Delay Release Pulse**
 - Set the delay release position. Such as the release position pulse is 1200, and delay release pulse is 200, the actual release pulse is the 1200-200. It is that the yarn is released on the 1000 pulse position.

- **Comb Hook Failed Row**
 - Set the rows of comb hook failed. If comb stitch drop in advance in this rows range, there is the alarm of “hook yarn faild”; if comb stitch drop after this rows range, system will think normal drop yarn.
 - Setting principle: Estimate the needful knitting rows which is comb from the highest position to release position. For example, the knitting rows sre 50, rows can be set to less than or equal to 45. Setting rows are less a few lines which compared with the actual number of lines. If deviation between the setting rows and the actual rows is too large to accurately alarm
 - Range: 0~100

- **L/R-Clip 1 Highest Pulse**
 - Set the additional pulses of left/right clip 1 after rised to the highest position.

- **L/R-Clip 2 Highest Pulse**
 - Set the additional pulses of left/right clip 2 after rised to the highest position.

- **1~100 Pin Pull**
- **101~200 Pin Pull**
- **201~300 Pin Pull**
- **301~400 Pin Pull**

- **401~500 Pin Pull**
- **More Than 500 Pin Pull**
 - Set the pull when the pattern needles are within each area.

- **L-Clip 1/2 Park**
- **R-Clip 1/2 Park**
 - Set the parking position of the left/right clip 1/2. Positive number is down, negative Numbers is up.

- **Cut over zero pulse**
 - Set the additional pulses of cuts after exceeded zero position.

- **Comb Brake Rows**
 - Set the rows value which is comb keep brake rows after from the highest position to the safety position
 - Range: -2-2

- **Test Menu Modify Enable**
 - Set whether the modify parameters on the testing interface is effective. If the value is “Yes”, comb parameters can be modified on the comb testing interface.

Comb parameters (More Parameters):

Cut Reset Speed(HZ)	5000	Clip Reset Speed(HZ)	5000
Cut Act Speed(HZ)	7000	Clip Act Speed(HZ)	7000
Cut Hold Current(A)	0.0	Clip Hold Current(A)	0.0
Cut Act Currents(A)	1.2	Clip Act Current(A)	1.2
Have Brake	NO	Comb Hold Torque(%)	-15
Encode Max Change Value	200	Encode Min Change Value	0
Comb Zero Pos Pull Rows	5	Comb Module Enable	No
Comb Module Mode	1x1	Elastic Yarn No.	0
Comb Module Dumu Segment	0	Hang Fabric Interval Needle	0
Comb Module Safety Pin	0	Cut Clip Mode	Normal
Clip Num	8	Clip Press Spacing(Inch)	0.00
Clip Density	0	Clip Press Spacing(Inch)	0.00
Press Needle Pos.(mm)	0.00	Start Knit One More Tubular	NO
Warning POS	0		

F1
F2
F3
F4
F5
F6 More Param

➤ **Cut/Clip Reset Speed (HZ)**

- Set the rise and fall speed of cuts/clips when reset. The greater the value, the faster the speed.

➤ **Cut/Clip Act Speed (HZ)**

- Set the rise speed of cuts/clips when hook yarn. The greater the value, the faster the speed.

➤ **Cut/Clip Hold Currents (A)**

- Set the holding currents of cuts/clips when don't work. The greater the value, the greater the currents.

➤ **Cut/Clip Act Currents (A)**

- Set the running currents of cuts/clips when rise to hook yarn. The greater the value, the greater the currents.

➤ **Have Brake**

- Set whether comb has a brake. "0" is NO; "1" is YES.

➤ **Comb Hold Torque (%)**

- When the comb brake is released, the upward equilibrium torque is used to offset the comb self-weight.

➤ **Encode Max Change value**

- Each knitting row the maximum distance of comb travel. Before reaching the drop yarn position, each row the maximum change of the comb encoder value (Maximum distance of the drop), if it exceeds the amount of change of this setting, the system alarm "from the comb drops too fast"
- Range: 0~500

➤ **Encode Min Change value**

- Each knitting row the minimum distance of comb travel. In the process of comb is drop to the dropping stitch position from the safety position, the changed minimum value of each comb coder (the dropping minimum distance of the each comb)
- Range:0~100

➤ **Comb Zero pull Rows**

- In process of knitting one cloth, the permissible maximum rows when comb doesn't pull

down. If the encoded value of the change in value of the comb (Decreased distance) is continuous to the number of lines is less than the smallest change in encoder (Decreased the minimum distance), System alarm "comb encoder exception".

- Range: 0~100
- **Comb Module Enable**
 - Set whether the comb module is effective
- **Comb Module Mode**
 - Set the type of comb module, such as 1X1, 2X2 etc. When the “Comb Module Enable” is the “Enable” option, this parameter is effective.
- **Elastic yarn No.**
 - Set the carrier number with elastic yarn, When the “comb module mode” is used (“Comb Module Mode” is not zero).
 - Range:1~32
- **Comb Module Density Segment**
 - Set the Density section of comb module.
 - Range: 1~128
- **Hang Fabric Interval Needles**
 - When the “Comb Module Mode” is not zero, this parameter is effective. When the elastic yarn is knitted, set the interval needles between adjacent duck.
 - Range:”1” is the front duck mode; “2” is the “Comb Module Mode”.
- **Comb Module Safety needles**
 - Set the safety needles of comb module
- **Cut Clip Mode**
 - Set the mode of cuts and clips
- **Clip Number**
 - Set the number of the clip
- **Clip Spacing (Inch)**
 - Set the spacing distance between clips.

- **Clip Density**
 - Set the density section of clips

- **Clip Press Spacing (Inch)**
 - Set the spacing distance when clip press needles.

- **Press needle position (mm)**
 - Set the position of pressing needle

- **Start Knit One More Tubular**
 - Set whether one more tubular is knitted, when knit with comb

- **Warning Position**
 - Set the position of comb drop fabric encode. When comb is working, if the signal of drop fabric has not been inducted above the warning position, there is alarm.

3.4.  Check

3.4.1.  Output Testing

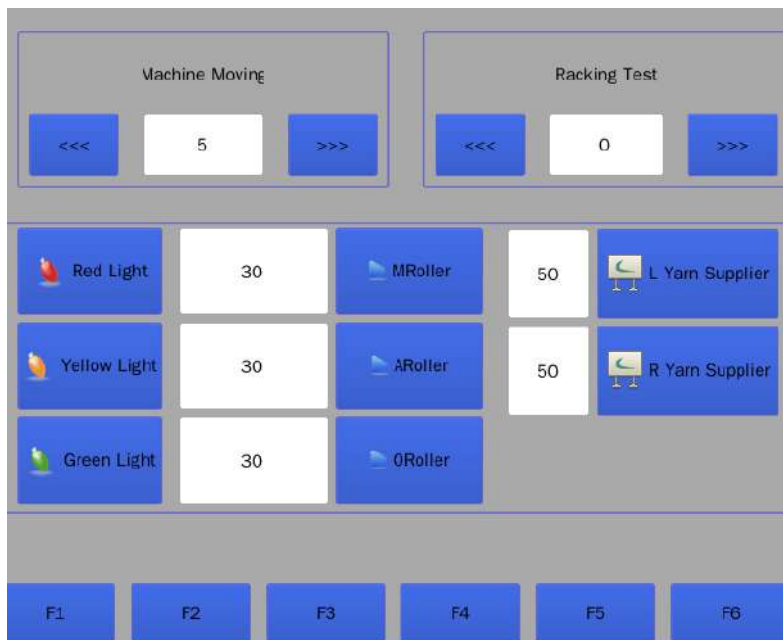

- Test servo, roller, lamp, yarn feeder, the keyboard used state
- Test whether carriage moving and racking direction is correct which compared with the inputting value (set the main motor servo direction).

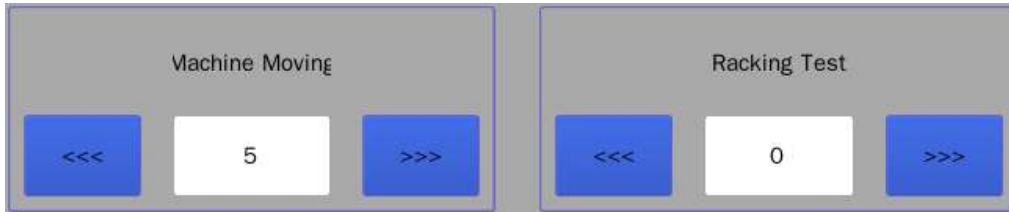

➤ **Carriage Instructions:**

- 1) the white text box can be set to carriage movement speed, range 5~15
- 2) <<< The head moves to the left/stop, >>> the head moves to the right/stop, the left and right direction can be switched in process of moving.
- 3) Carriage continues to move until the left and right anti-collision switch is triggered, then the servo power failure, and carriage stop moving
- 4) When servo has no electricity, alarm "servo is not open"

➤ **Racking Instructions:**

- 1) Input the racking needles in the white text, range 0~8
- 2) Click on the button <<<, the needle bed rack to the left. Click on the button >>>, the needle bed rack to the right.
- 3) The number of inputting needles is "0", the needle bed reset.
- 4) When servo has no electricity, alarm "servo is not open".

Note: When test racking, the needle bed should not has the front and back stitch.



➤ **Signal light**

- Observe the light color. Whether is the light color corresponding to machine state?

- Red light: Fault stop machine model, Alarm buzzer warning
- Yellow light: Running preparation model, control lever stop
- Green light: Common knitting mode, control lever start

➤ **Roller test**

- Test the roller motor speed and direction
- Instructions: Positive number is positive rotation, negative number is negative rotation

➤ **Yarn supplier test**

- Test the act of yarn supplier

3.4.2.  **Input Testing**



Main Motor Error Singal	<input type="checkbox"/> On	Racking Limit Singal	<input type="checkbox"/> On	Yarn Broken Singal	<input type="checkbox"/> On
Main Motor Reedy Singal	<input type="checkbox"/> On	Racking Zero Pos Singal	<input type="checkbox"/> On	Needle Zero Pos Singal	<input type="checkbox"/> Off
Racking Motor Error Singal	<input type="checkbox"/> On	L Tension Device Singal	<input type="checkbox"/> On	F Probe Singal	<input type="checkbox"/> On
Racking Motor Reedy Singal	<input type="checkbox"/> On	R Tension Device Singal	<input type="checkbox"/> On	B Probe Singal	<input type="checkbox"/> On
Handle High Start Singal	<input type="checkbox"/> On	R Supp Y Broken Singal	<input type="checkbox"/> On	Protect Door Singal	<input type="checkbox"/> On
Handle Stop Singal	<input type="checkbox"/> On	L Sup Y Braoken Singal	<input type="checkbox"/> On	Yarn Knob Singal	<input type="checkbox"/> On
Handle Low Start Singal	<input type="checkbox"/> On	Machine L Limit Pos Singal	<input type="checkbox"/> On	Fabric Rewind Singal	<input type="checkbox"/> On
Emergency Stop Singal	<input type="checkbox"/> On	machine R Limit Pos Singal	<input type="checkbox"/> On	Needle Pos Count	0



- **F1 Key Board:** the key board is corresponding to the screen button. Press the some button on the key board, than the corresponding screen button has change. If no change, key board can has been broken or poor contact.
- **F2 Touch Screen:** Whether does the touch screen fully display?

Input signal Instructions:

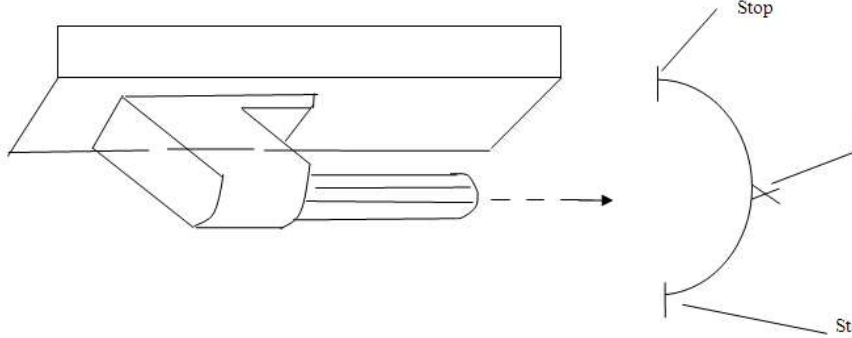
Main motor Error signal	The main servo motor error signals return back to the test after powered on ◆ on: No error ◆ off: Error
Main motor Ready Signal	The main servo motor ready signal return back to the test after powered on ◆ on: No error ◆ off: Error
Racking motor error signal	The main racking servo motor error signal return back to the test after powered on ◆ on: No error ◆ off: Error
Racking motor ready signal	The racking servo motor ready signal return back to the test after powered on ◆ on: No error ◆ off: Error
Handle High-start \stop\slow signal	The pull lever signal test in each position, refer to the following fig. Stop: Trolley counter-clockwise to the maximum position The slow-motion: Rod clockwise to the middle position Start: Rod clockwise to the maximum position  ◆ on: Not in the position ◆ off: In the position
Emergency stop signal	Emergency stop button signal test. Manually press emergency stop button to the emergency stop position, check whether the signal is in “Close” status ◆ on: No Emergency stop ◆ off: Emergency stop
Racking limit signal	Racking limit signal detection is the maximum distance of the racking. When the racking is beyond this distance, the alarm "shaker limit" will appear. Use small metal tools or move the carriage to the top of the racking limit sensor to check whether the signal is in "Close" status ◆ on: No limit signal

	<ul style="list-style-type: none"> ◆ off: limit signal
Racking zero signal	<p>Use small metal tools or move the carriage to the top of the racking limit sensor to check whether the signal is in "Close" status. After finishing reset, the signal is "Close" status. When the racking sensor chip is in the right of this position, the signal has been "closed" status, when on the left. The signal has been "open" state.</p> <ul style="list-style-type: none"> ◆ on: No racking zero position signal ◆ off: Racking zero position signal
Left/Right Tension Device Signal	<p>Left and right tension signal detection test on the knitting machine. When the left and right take-up yarn spring expose to alarm wire position, the signal is "closed" state</p> <ul style="list-style-type: none"> ◆ on: No yarn breakage signal in left and right ◆ off: Yarn breakage signal in left and right
Left/Right supplier Yarn Broken Signal	<p>Check the yarn broken signal of left/right supplier. Open the spring of left/right yarn supplier, the sensor was lit</p> <ul style="list-style-type: none"> ◆ on: NO yarn broken signal of left/right supplier ◆ off: yarn broken signal of left/right supplier
Machine Left/right limit Position signal	<p>Maximum stroke of the head in left and right direction, the left and right limit signal detection, left limit is stop bit when the head reset. Move Small metal appliances or the head to the top of the left and right limit sensor to check whether the signal is in "Close" status</p> <ul style="list-style-type: none"> ◆ on: No limit signal ◆ off: Limit signal
Yarn broken signal	<p>Yarn tension broken yarn signal test. Put up take-up spring of yarn tension to the alarm location of the broken yarn</p> <ul style="list-style-type: none"> ◆ on: No yarn breakage signal in yarn tension ◆ off: Yarn breakage signal in yarn tension
Needle zero position signal	<p>Check Needle zero signal. The needle zero position is fixed, manually move the carriage to needle zero position, check whether the needle zero position signal is in "Close" status</p> <ul style="list-style-type: none"> ◆ on: No needle zero position signal ◆ off: Needle zero position signal
Front/Back Probe Signal	<p>The carriage test floating yarn with probe, toggle probe, observe the signal state</p> <ul style="list-style-type: none"> ◆ on: No offset ◆ off: Offset
Protect Door Signal	<p>Test Protected door closing\opening state</p> <ul style="list-style-type: none"> ◆ on: close ◆ off: open
Yarn Knot signal	<p>Yarn tension knot signal test, push yarn tension knot sensor chip to the alarm location (Coarse knot need to have appropriate alarm device).</p> <ul style="list-style-type: none"> ◆ on: No knot signal in yarn tension ◆ off: Knot signal in yarn tension
Fabric Rewind Signal	<p>Roller roll fabric signal test</p> <ul style="list-style-type: none"> ◆ on: No cloth rolled ◆ off: cloth rolled
Needle position Count	<p>Display the needle number which correspond to the left position of the stopping carriage</p>

3.4.3.



Carriage Testing



- **Carriage testing instructions:** Machine parts testing menu can test all running mechanism of the carriage, including stitch stepper motor, stepper motor, carriage cam electromagnet, yarn feeder electromagnet, needle selection electromagnet etc.
- **F1 Single Cycle**
 - Selector/ cam /carrier electromagnets cycle to action in self-group.
 - Step: Select the needful cycle electromagnet button (selectors, cams or carriers). Click “F1 single cycle” or press F1 key, selected single electromagnet group will cycle to action. Click “F1 single cycle” or press F1 key again to stop cycle.
- **F2 All Cycle**
 - All electromagnets (Selector, cam and carrier electromagnet) cycle to action
 - Step: Click “F2 all cycle” or press F2 key, all electromagnets will cycle to action (not include of the density motor). Click “F2 all cycle” or press F2 key again to stop cycle.
- **F3 All Density**
 - All density motors regularly cycle
 - Step: Click “F3 all density” or press F3 key, all density motors will cycle to action (not include of the density motor). Click “F3 all density” or press F3 key again to stop cycle.

➤ **F4 Self-Check**

- Check whether all electromagnets and density motors are short circuits, power off etc.
- Step: Click “F4 Self-Check” or press F4 key, all parts in the carriage start to cycle to reset testing. After finishing testing, the test results interface will be displayed.

- **F5 Open 24V**

- When the alarm appear, the carriage will close the 24v voltage, because of the protecting of exceed the allowable current. Click “F5 Open 24V” or Press F5 key, the 24v voltage will be reopened.



Note: When the new machine is installed, the carriage should be performed complete tested

3.4.4.



Comb Testing

L/R Cycle: left/right clips and cuts reset in turn

When comb is rising, main roller must be opened

Manually test comb rise and drop

Sensor and pulse value of hook position, safety position, release 1/2 position and zero

➤ **F1 Carriage Back Edge**

- **Instructions:** When carriage is in the knitting area and not in the left limit position, click “F1 Carriage Back Edge” or press F1 key, carriage will automatically move to the left limit position.

➤ **F6 Auto Write**

- **Instruction:** Automatically input the pulse value of comb current position to the selected text box.

3.4.5.  **Voltage Testing**

➤ **Monitoring a various of system voltage**

M Controller	AD Value	Voltage	Carriage	Voltage
3.3V	602	3.21	3.3V	0.23
5V	708	5.26	5V	5.19
12V	626	11.91	15V	14.95
15V	623	14.86	24V	23.74
24V	666	23.39	-24V	-23.02
S15V	0	0.00	Carriage State	0
ACV	602	118.26	Carriage Needle Crush1	0
MPCS	25		Carriage Needle Crush2	0
I1	273		Current	
I2	446		Density Current(A)	-48.46
Needle Crush 1	0		Triangle Current(A)	-48.20
Needle Crush 2	0		Carrier Current(A)	0.00
Roller Version	0			

F2
F3
F4
F5
F6

3.5.  **File**

3.5.1.  **File Management**



Note: Support the file folder in U disk. Directory Up: Enter the superior folder. Directory Down: Enter the lower folder. File type is 001/CNT.

- **F1 Select:** Just select the pattern from the memory.
- **F2 Export:** Export the pattern from the memory to the U disk.
- **F3 Import:** Import the pattern from U disk to the the memory.
- **F5 Delete:** Delete any selected pattern in the memory.
- **F6 Empty:** Delete all patterns in the memory.

3.5.2. Knitting Plan



➤ **Knitting plan instruction:**

- 1) The left list is the memory pattern list, the right list is the pattern list of participate in knitting plan
- 2) In the plan pattern list “Time” is the knitted number of the current line pattern in each knitting cycle plan
- 3) In the plan pattern list “supplement piece” can change the knitted number of the current line pattern, the actual number is “time”+” supplement piece”, supplement piece is executed only once, not involved in knitting planning cycle
- 4) The knitting plan number: The all number of the current knitting plan
- 5) Knitted cycle of the knitting plan: The number which has been executed in the current knitting plan
- 6) When the cycle number of knitting plan equal to Knitted cycle of the knitting plan, the run interface alarm “knitting plan has finished”, canceling the alarm need cancel knitting plan or reset each cycle.
- 7) Knitting parameter follow: when the cycle knitting is carried out, whether knitting parameter follow.



Note: cycle one time is that all patterns in "knitting plan" list are knitted one time according to times (including the supplement piece number)

- **F1 Add:** Select the pattern in the memory, move the selected pattern to knitting plan.
- **F2 Delete:** Select the pattern in the knitting plan, delete to the selected pattern.
- **F3 Plan Invalid:** Set whether the knitting plan is effective.
- **F4 Parameters Follow:** When some pattern is knitted, whether does the knitting parameters of this pattern follow?
- **F5 Start Needle Position Follow:** Whether is all patterns in knitting plan the same start needle position?

3.5.3.

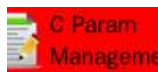

Parameters management

- **Parameters management instruction:** Import various parameters of the flat knitting machine from the U disk to the memory. Or export various parameters of the flat knitting machine from the memory to the U disk.



3.5.4.



Produce Information

	Code	Priority	Time	Content
1	77	0	2015-04-17 10:31:16	Please Read Pattern
2	77	0	2015-04-17 09:37:00	Please Read The Pattern
3	77	0	2015-04-17 09:36:55	Please Read The Pattern
4	77	0	2015-04-17 08:53:37	Please Read Pattern
5	0	0	2015-04-14 12:45:13	Please Read The Pattern
6	0	0	2015-04-14 12:35:00	Please Read The Pattern
7	0	0	2015-04-13 17:38:42	Please Read The Pattern
8	0	0	2015-04-13 17:37:30	Please Read The Pattern
9	0	0	2015-04-13 17:31:55	Please Read The Pattern
10	0	0	2015-04-13 17:27:57	è?-è?????è?±??-??????

Navigation buttons: Up, Down, PgUp, PgDn, Page:1

Function buttons: F1 Statistics, F2 Similar Info, F3 History Logs, F4 Day Logs, F5 Delete Logs, F6

- **Instruction:** View all alarms in the process of production, and information can be classification display.
 - 1) Click the display position of logs or click the “Up”/“Down” button to select record. Red is selecting
 - 2) Click or press the “PgUp”/“PgDn” button to select flip query
 - 3) Click “F1 statistics” or press F1 key, statistics information according to the current

information type

- 4) Click “F2 Similar Information” or press F2 key. Show the detailed information which is the same as the current type
- 5) Click “F3 History Logs” or press F3 key. Show all logs.
- 6) Click “F4 Day Logs” or press F4 key. Show today’s logs.
- 7) Click “F5 Delete Logs” or press F5 key. Delete all logs.

3.5.5.  Parameters Copy

Storage Param			Pattern File		
	Name	Date		Name	Date
1	8X8b.ppp	2015-09-14 15:17	1	4455.001	2015-09-25 10:04
2	4455.ppp	2015-09-14 15:17	2	8X8b.001	2015-05-14 12:51
3	927KSA1.ppp	2015-09-14 15:15	3	Encry1.001	2015-05-14 12:51
4	1200.ppp	2015-07-04 09:13	4	12GDX3P.001	2015-05-14 12:51
5	12GDX3P.ppp	2015-07-01 16:46	5	b3.001	2015-05-14 12:51
6	Encry1.ppp	2015-07-01 16:46	6	Q.001	2015-05-14 12:51
7	b3.ppp	2015-07-01 16:45	7	1200.001	2015-04-01 17:37
8	Q.ppp	2015-07-01 16:33	8	wyx_PCS.001	2014-07-19 20:53
9	322p11.ppp	2015-04-01 17:36	9	S-36.001	2014-02-25 01:29

F1 Param Copy
F2 PgUp
F3 PgDn
F4
F5 PgUp
F5 PgDn

- **Instruction:** Copy the knitting parameters of pattern to other pattern in the memory. In the left side the file has needful parameters, in the right side the pattern file need to copy parameters. Select the parameter file and pattern file in the both side, click “F1 Param Copy” or Press F1 key to finish parameter copying

3.5.6.  Net Pattern

- **Instruction:** Patterns on the left is in the memory, Patterns on the right is on the server.

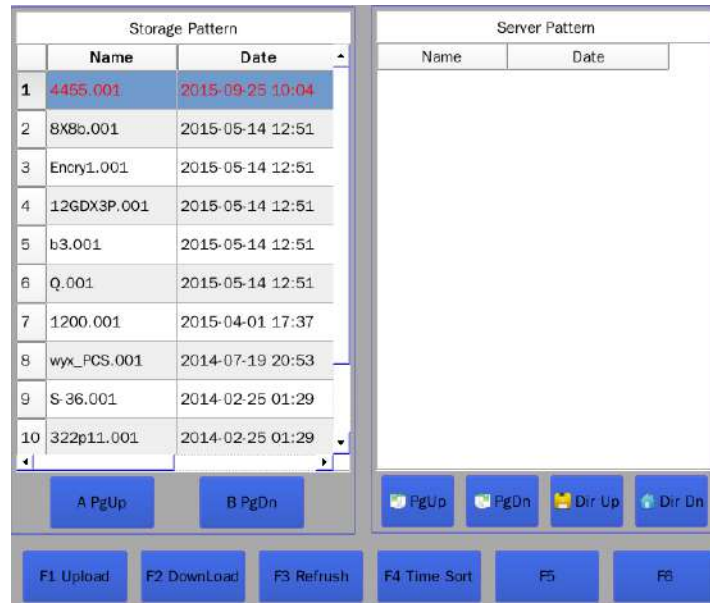

- **F1 Upload:** Load the pattern from the memory to the server.
- **F2 Download:** load the pattern from the server to the memory.
- **F3 Refresh:** Refresh patterns on the current server
- **F4 Time Sort:** According to the system time, sort the pattern.

3.6. Machine

3.6.1. Senior Parameters

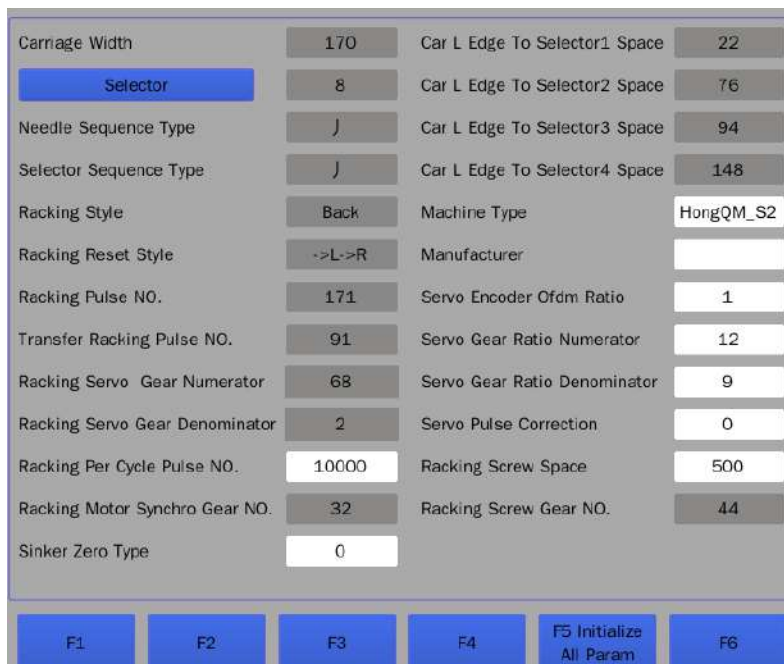

Note: Machine parameters are set when the machine leave factory, please don't easily change.

➤ **Carriage Width**

- Show the carriage width from left limit to right limit, it cannot be modified

➤ **Selector**

- Display the section number of the selector.

➤ **Needle Sequence Type**

- Set needle sequence type in needle board.
- There are two sequence types (“ / ” or “ \ ”), it cannot be modified

➤ **Selector Sequence Type**

- Set selector blade sequence type.
- There are two sequence types (“ / ” or “ \ ”), it cannot be modified

➤ **Racking Style**

- Set the racking type.
- Range: 0-Front rack; 1-Back rack; 2-Doubke rack

➤ **Racking Reset Style**

- Set the racking reset type
- Range: 0- Left is more preferential than right; 1- Right is more preferential than left

➤ **Racking pulses NO.**

- Display the racking pulses. It cannot be modified.

➤ **Transfer Racking pulses NO.**

- Display the transfer racking pulses. It cannot be modified.

➤ **Racking Servo Gear Numerator/ Denominator**

- Display racking servo gear numerator/ denominator. It is similar to the main servo motor set

➤ **Racking Per Cycle Pulse NO.**

- The pulse of that racking motor turn one circle. System automatic calculation. Don't user need set.

- **Racking Motor Synchronous Gear No.**
 - Display and set the actual gear number of the racking motor synchronous gear

- **Sinker Zero Type**
 - Set the Sinker type, it is the up and down type or the left and right type.

- **Carriage Left Edge to Selector 1/2/3/4 space**
 - Show the carriage left side to selector size (needle). It cannot be modified

- **Machine Type**
 - Display the machine model. It cannot be modified

- **Manufactures**
 - Display the machine manufacture information.

- **Servo Encoder OFDM Ratio**
 - Display orthogonal frequency division multiplexing ratio of the main servo

- **Servo Gear Ratio Numerator/ Denominator**
 - Display numerator and denominator of the main servo electronic gear

- **Servo Pulse Correction**
 - Set the servo pulse correction.

- **Racking Screw space**
 - Set the distance of the racking screw

- **Racking Screw Gear NO.**
 - Display the synchronous gear number of the racking screw.

3.6.2. Internet Setting

- Manufacturers only installed the internet platform function of our company (additional fees) to set the parameters.

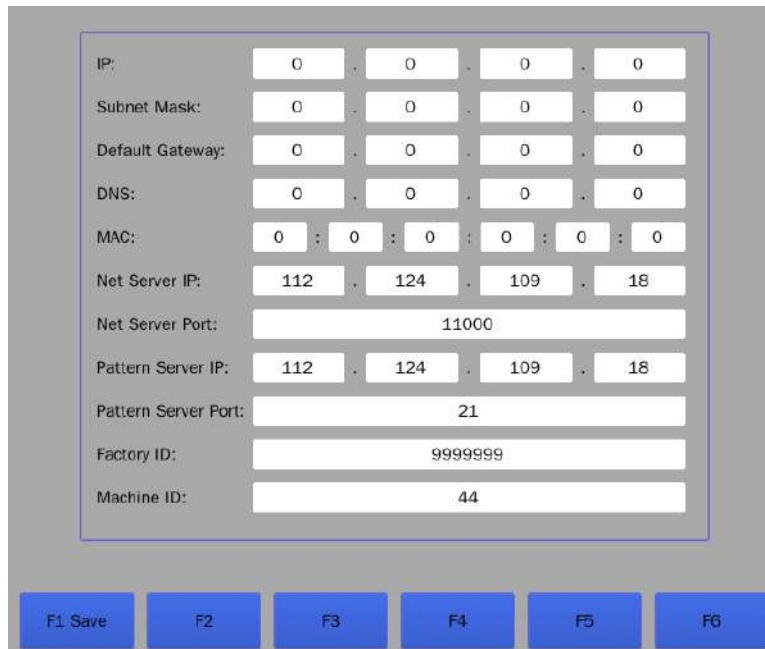

3.6.3. Upgrade



Instruction:

- 1) The current version can be viewed.
- 2) Upgrade program: If upgrade file is in the root directory, select the corresponding upgrade button. If upgrade file is in the folder, click “Directory Up” to enter and upgrade after selected the folder.
- 3) When the upgrade process is interrupted or failure, the current system will not be affected. System can upgrade again.

3.6.4. Machine Setting (Payment by installment)

➤ Manage each program according to the date used. The time is set by mechanical factory.

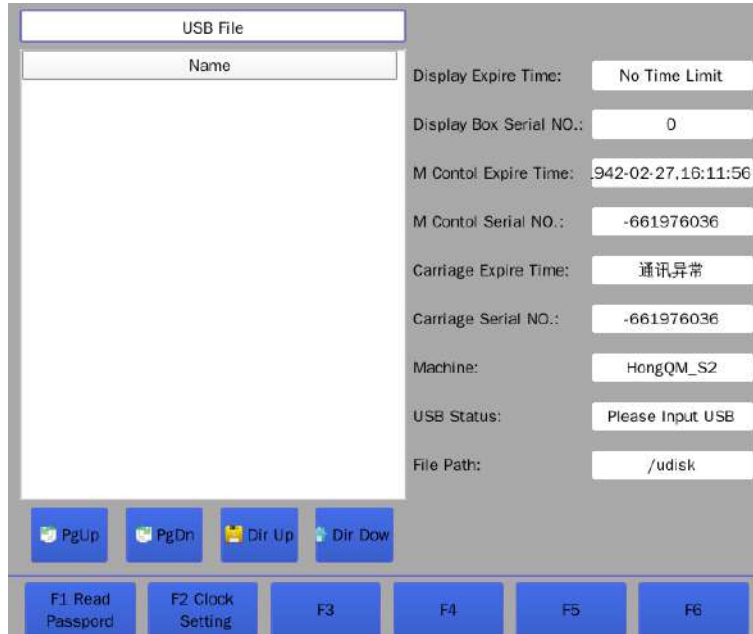

3.6.5. Machine Configuration



- **F1 Import Config File:** Import the configuration file from U disk to the memory.
- **F2 Export Config File:** Export the configuration file from memory to the U disk.

Machine Configuration Instruction:

- **Selector Act time (ms)**
 - Set the electric time of the electromagnet when the selector selects needles.
 - Range: 1.0~3.0

- **Selector Off time (ms)**
 - Set the electric time of the electromagnet when the selector returns pressure needles.
 - Range: 1.0~3.0

- **Yarn Lift time (ms)**
 - Set the electric time of the electromagnet when the yarn feeder electromagnet lift
 - Range: 15~90

- **Yarn Drop time (ms)**
 - Set the electric time of the electromagnet when the yarn feeder electromagnet drop off
 - Range: 15~90

- **Transfer Act Time (ms)**
 - Set the electric time of the electromagnet in process of transfer
 - Range: 15~90

- **Transfer off Time (ms)**
 - Set the electric time of the electromagnet in process of knitting
 - Range: 15~90

- **Receive/Lift Electromagnet Drive Time (ms)**
 - Set the electric time of the electromagnet in process of receive/lift
 - Range: 15~90

- **Receive/Lift Electromagnet Cut Time (ms)**
 - Set the power failure time of the electromagnet in process of receive/lift
 - Range: 15~90

- **Tuck Act Time (ms)**
 - Set the electric time of the tuck electromagnet

- Range: 15~90

- **Tuck Off Time (ms)**
 - Set the power failure time of the tuck electromagnet
 - Range: 15~90

- **2 Density Act Time (ms)**
 - Set the electric time of the second density electromagnet
 - Range: 15~90

- **2 Density Off Time (ms)**
 - Set the power failure time of the second density electromagnet
 - Range: 15~90

- **Density Speed (HZ)**
 - Set the speed of density motor
 - Range: 1~20000

- **Density Working current (A)**
 - Set the current when the density motor is working
 - Range: 0.4~1.5

- **Density Hold current (A)**
 - Set the current when the density motor keep hold
 - Range: 0.1~0.8

- **Sinker Speed (HZ)**
 - Set the speed of sinker motors
 - Range: 1~20000

- **Sinker Working current (A)**
 - Set the current when the sinker motor is working
 - Range: 0.4~1.5

- **Sinker Hold current (A)**
 - Set the current when the sinker motor keep hold
 - Range: 0.1~0.8

➤ **Triangle Speed (HZ)**

- Set the speed of cam motors
- Range: 1~20000

➤ **Triangle Working current (A)**

- Set the current when the cam motor is working
- Range: 0.4~1.5

➤ **Triangle Hold current (A)**

- Set the current when the cam motor keep hold
- Range: 0.1~0.8

➤ **Roller Frequency Division**

- Set the speed of the roller motor. The value is smaller, the speed is faster.
- Range: 0~8 (1 frequency division ~256 frequency division)

Roller Pulse Type	Monopulse	Front Probe Correction	0.0
Roller Hold Current(A)	3.0	Back Probe Correction	9.8
Roller Act Electric Current(A)	5.6	ARoller Open Hold Force	-10
Roller Max Frequency(Hz)	200000	ARoller Close Hold Force	10
Servo Stop Delay Time(ms)	150	Servo Mode	0
Servo Off Delay Time(ms)	50	Racking Highest Frequency	10000
Shield Doff Door Alarm	NO	Crush Sensor POS	Board
Motor Carrier	NO	MRoller.Sensor	NO
Carrier Motor Speed(Hz)	6000	Y-Motor Act Current(A)	2.4
Y-Motor Hold Current(A)	0.8	Dumu Act In Correction	5.00
Dumu Act Out Correction	0.00	Dumu Max Value	600
Sinker Max Value	400	Probe Type	Normal
Comb Pull Force	1	Comb Pull Force	1
Pown-down Voltage	0.00	Enhanced Probe Delay	0
Network Enable	1	MServo Motor Max Speed	0

F1 Import Config File
F2 Export Config File
F3
F4
F5
F6 More Param

Machine Configuration (More Parameters):

➤ **Roller pulse type**

- Set the roller pulse type
- Range: 1-single pulse; 2-double pulse.

➤ **Roller Hold current (A)**

- Set the current when the roller keep hold
- Range: 0~6.0

➤ **Roller Act Electric current (A)**

- Set the current when the roller is running
- Range: 1.0~6.0

➤ **Roller Max Frequency (HZ)**

- Set the max frequency of the roller
- Range: 1~25000

➤ **Servo Stop Delay Time (ms)**

- Set the delay time of servo stop when the machine stop
- Range: 0~200

➤ **Servo Off Delay Time (ms)**

- Set the delay time of servo stop when the machine power off
- Range: 0~200

➤ **Shield Doff Door Alarm**

- When doff door is opened, whether does system alarm?
- Range: “No” don’t alarm; “Yes” alarm.

➤ **Motor Carrier**

- Set whether the control carrier type is the motor.
- Range: “0” is “No”; “1” is “Yes”.

➤ **Carrier Motor Speed (HZ)**

- Set the speed of the carrier motor.
- Range: 1-8 gear. The used gear is 3-6 in general case

➤ **Y-Motor Hold Current (A)**

- Set the current value when the yarn motor is stands still.
- Range: 1.0 ~8.0

➤ **Density Act Out Correction**

- Amend the mechanical position of density slider. Amend the act point before getting out

the knitting area.

- Range: -20~20mm

➤ **Sinker Maximum value**

- Set the sinker maximum value

➤ **Comb Pull Force**

- Set the comb-pull type
- Range: “0” is the torque type; “1” is the QEI type.

➤ **Power-Down Voltage**

- When the machine power supply voltage is less than the set value, system automatic power down
- Range: 0~200V

➤ **Front/Back probe correction**

- Correct the distance that the front/back probe correspond to the left side of carriage
- Range: -100.0~100.0 Inch

➤ **Auxiliary Roller Open Hold Torque**

- Set the torque value that the auxiliary roller keep opening
- Range: -100~0

➤ **Auxiliary Roller Close Hold Torque**

- Set the torque value that the auxiliary roller keep closing
- Range: 0~100

➤ **Servo Mode**

- Set the servo mode

➤ **Racking Highest Frequency**

- Set the highest speed of the racking motor
- Range: 1000~150000

➤ **Crush Sensor Position**

- Set the crush sensor position.
- Range: Needle board or carriage.

➤ **Main Roller Sensor**

- Set whether have the sensor of the main roller opening or closing.
- Range: “0” is “No”; “1” is “Yes”.

➤ **Y-Motor Act Current (A)**

- Set the acting current value of the carrier motor. The greater the current, the greater the strength. The smaller the current, the smaller the strength.
- Range: 0.2~1.5

➤ **Density Act In Correction**

- Amend the mechanical position of density slider. Amend the act point before getting in the knitting area.
- Range: -20~20mm

➤ **Density Max Value**

- Set the maximum density value.
- Range: 180~600

➤ **Probe Type**

- Set the probe type.
- Range: “0” is the normal type; “1” is the enhanced type.

➤ **Comb Pull**

- The minimum value of the comb-pull every row. If the comb-pull is less than the value, system will automatically increase the comb torque.
- Range: 1-100

➤ **Enhanced Probe Delay**

- The mechanical response time of the enhanced probe. Now the time is 10-50ms in general case.
- Range: 1-100ms

3.6.6. Select Language

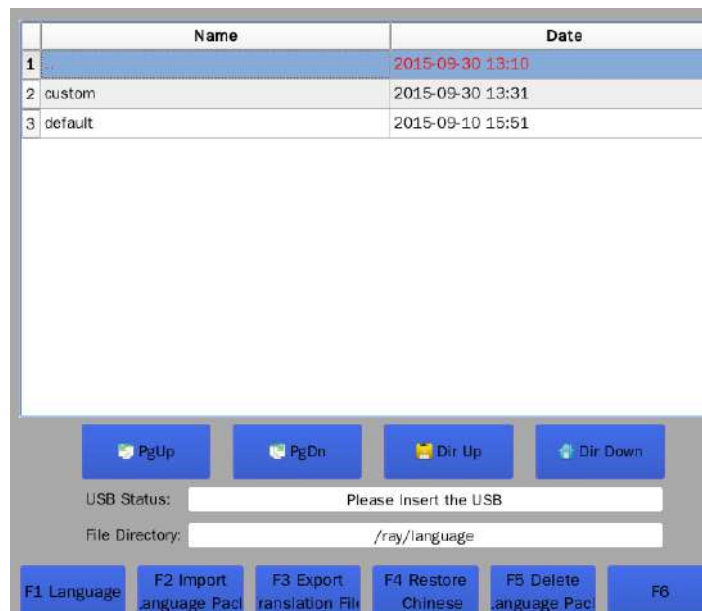

Instruction:

➤ F1 Language

- Select the language file from the file list on the U disk.

➤ F2 Import Language Package

- Import the selected language file from U disk to the memory.

➤ F2 Export Language Package

- Export the selected language file from the memory to the U disk.

➤ F4 Restore Chinese

- Restore Chinese language on display screen.

➤ F5 Delete Language Package

- Delete the existing language package in the memory.

Common fault table

The necessary action before checking fault

1. Check whether the system switch is correct;
2. Check and confirm whether the program version is correct;
3. Check and confirm whether the machine parameters and system parameters is correct.

No.	Fault/alarm phenomenon	Failure analysis	Not
1	Chip transmits data error (Can communication error)	<ol style="list-style-type: none"> 1. Check whether the plug of carriage signal line is loose; 2. Check whether the CPU board of carriage is problem; 3. Check whether the 5V power supply is problem; 4. Check the main control board is problem. 	
2	Density motor failure	<ol style="list-style-type: none"> 1. Check whether the motor resistance value is normal with the a multimeter; 2. Check whether the motor circuit connection is normal with the a multimeter; 3. Replace the density motor; 4. Test whether the sensor signal is normal; 5. If the carriage has been take down, check whether the circuit connection is normal. 	
3	Main motor isn't ready signal	<ol style="list-style-type: none"> 1. Check and view whether the servo is the failure code; 2. Check the servo circuit connection 3. Replace the interface board; 4. Replace the servo. 	
4	Racking motor isn't ready signal	<ol style="list-style-type: none"> 1. Check and view whether the servo is the failure code; 2. Check the servo circuit connection 3. Replace the interface board; 4. Replace the servo. 	
5	Reads the USB pattern error	<ol style="list-style-type: none"> 1. Check whether the pattern file is problem; 2. Make U disk formatting and reimport the pattern; 3. Check whether the pattern file size is less than 5K. 	
6	Roller open error	<ol style="list-style-type: none"> 1. Check whether the opening sensor of the roller is normal; 2. Check whether the roller is stuck. 	
7	Doesn't work normally after restarting	<ol style="list-style-type: none"> 1. Illegally turn off the computer; 2. The time of turning off the computer is not long enough; 3. Replace the charging capacitor. 	
8	Cloth edge broken	<ol style="list-style-type: none"> 1. The yarn feeder park position is too far; 2. The carriage brush position is right or not; 3. There are the yarn balls or Debris; 4. The needle can be bad on the edge; 5. The stitch density is too loose or tight; 	

		<ul style="list-style-type: none"> 6. The carrier is too narrow or wide. The carrier is loose or not; 7. The side tension is too small; 8. The roller tension is too small; 9. Yarn is not completely covered with wax; 	
9	Drop stitch when knit	<ul style="list-style-type: none"> 1. The carriage brush is open the needle or not; 2. Needle is problem or not; 3. Carriers is too loose or not; 4. The roller tension is too large; 5. Stitch density is too loose; 6. Selector is problem (selector blade break); 7. The yarn feeder is not installed suitably (too high caused by dropping stitch, too low caused by striking needle) 	
10	Carriage strike Needle	<ul style="list-style-type: none"> 1. Check whether there is foreign body in the needle groove and the stitch is floating. 2. Check whether cam strike needle and knitting channel of the act cam is smooth 	
11	The carrier doesn't feed yarn	<ul style="list-style-type: none"> 1. The yarn feeder position is too high 2. The speed of yarn feeder is too fast. 	
12	Drop stitch when transfer	<ul style="list-style-type: none"> 1. Check whether the roller tension is too large; 2. Check the racking zero position; 3. Check whether the selector is working normally; 4. Check whether the racking speed is too fast. 	
13	Cloth take-up undesirable	<ul style="list-style-type: none"> 1. Check whether the cloth is falling; 2. Check whether the cloth is rewind into the roller 	
14	needle transfer	<ul style="list-style-type: none"> 1. Check the total pulses and the zero needle position; 2. Check selector correction; 3. Check whether the distance between the needle zero position sensor and magnetic steel is within 1mm~2mm range; 	
15	Regularly or frequently disorderly select needles	<ul style="list-style-type: none"> 1. Check whether the needle gauge and the carriage size is correct; 2. Check whether the needle array type is correct; 3. Check the selector position is correct and the angle offset; 4. Check the distance between the selector and needle board (view whether the needle butt is full pressed); 5. Check whether the circuit connection of the selector is normal; 6. Push the carriage with hand, check whether the position of pulling the needle out is correct; 7. Remove selector, check whether the hardware action is correct. 	
16	Irregularly or occasionally disorderly select needles	<ul style="list-style-type: none"> 1. Check the cleanliness of the needle board and cam. If the flying yarn is too much in the needle groove, the knitting 	

		<p>action is not smooth.</p> <ol style="list-style-type: none"> 2. Check whether the needle zero position changes. If it changes, inform the manufacturers. 3. In the high speed and low speed condition the same phenomenon has appeared, inform the manufacturers. 4. Disorderly select needles are in the special case, such as automatic zero etc. Inform the manufacturers. 	
17	take carrier failure or cast off	<ol style="list-style-type: none"> 1. Check the carrier electromagnet in machine test interface, view whether there are interaction in process of acting; 2. Check whether the carrier screw is loose; 3. Adjust parameters, such as the yarn park position, yarn down advance, rotary distance etc. 4. Check the multi-pieces expanding state, the phenomenon is caused by multi-pieces expanding. 5. The phenomenon is caused by a specific pattern, inform the manufacturers. 	
18	Carriage shake or unstable in running	<ol style="list-style-type: none"> 1. Adjust servo parameters; 2. Check that the servo circuit connection is normal. 	
19	Carriage can't reach the specified position (except for carriage dose not move, other is normal)	<p>The phenomenon is appear in the process of carriage speed switch</p> <ol style="list-style-type: none"> 1. Check whether the gear numerator/ denominator rate is correct; 2. Check whether the pulse correction is too small; 3. Check whether the belt is too loose 	
20	The problem about density	<ol style="list-style-type: none"> 1. Check whether the density cam run normally; 2. Check whether other institutions affect the density motor running 	
21	Selector board burn	The carriage program is later than 20511 version or not.	
22	Comb tension is unstable, or machine sudden power failure	Check the stable of the city voltage, test with voltage stabilizer	
23	Floating cloth	<ol style="list-style-type: none"> 1. Check whether the roller is normal; 2. Check whether the density motor is normal; 3. Check whether the sinker motor is normal. 	
24	Abnormal alarm	Check whether there are multiple alarms and the alarm window is hidden. Inform the manufacturers.	
25	Comb	<ol style="list-style-type: none"> 1. Check whether the position of all comb sensors and the comb parameters are correct; 2. Check whether comb parameters are set reasonable. 3. The comb hooking yarn is strong enough or not; 4. Check whether the action about roller is correct. 	

Appendix I

1. Set total pulses through the carriage position

- 1) The first needle position of the total pulses. The left side or cam of the carriage corresponds to the left inner edge of the first needle groove (According to the actual carriage size). The following picture is that the carriage cam corresponds to the first needle position.
- 2) The last needle position of the total pulses. The left side or cam of the carriage corresponds to the left inner edge of the last needle groove (According to the actual carriage size).

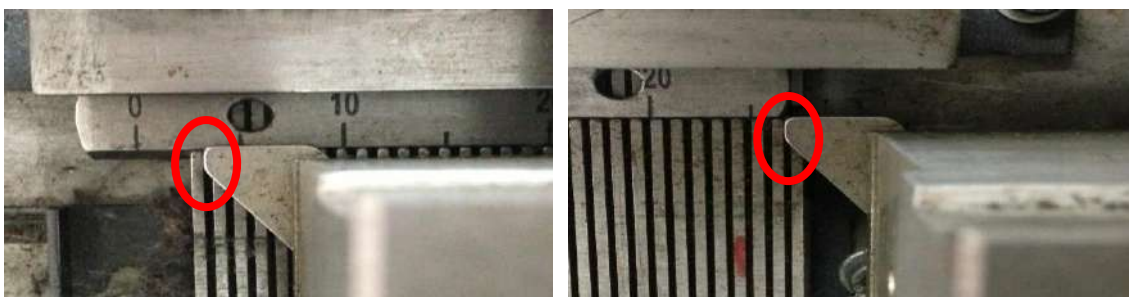

2. Set Needle Origin position through the carriage position

The left side or cam of the carriage corresponds to the left inner edge of the first needle groove (According to the actual carriage size).



Special description: if the selector size is measured by the left side of the carriage, total pulse and needle origin position is all measured by the left side of the carriage; if the selector size is measured by the left cam of the carriage, total pulse and Needle Origin position is all measured by the left cam of the carriage.

Appendix II knitting principle

1. Needle structure and needle selection corresponds to the selected pin relation

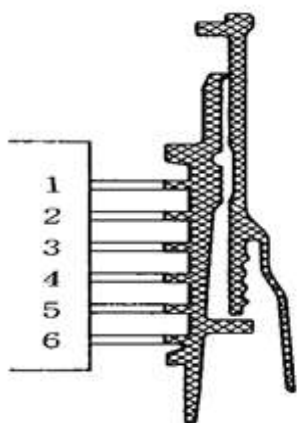
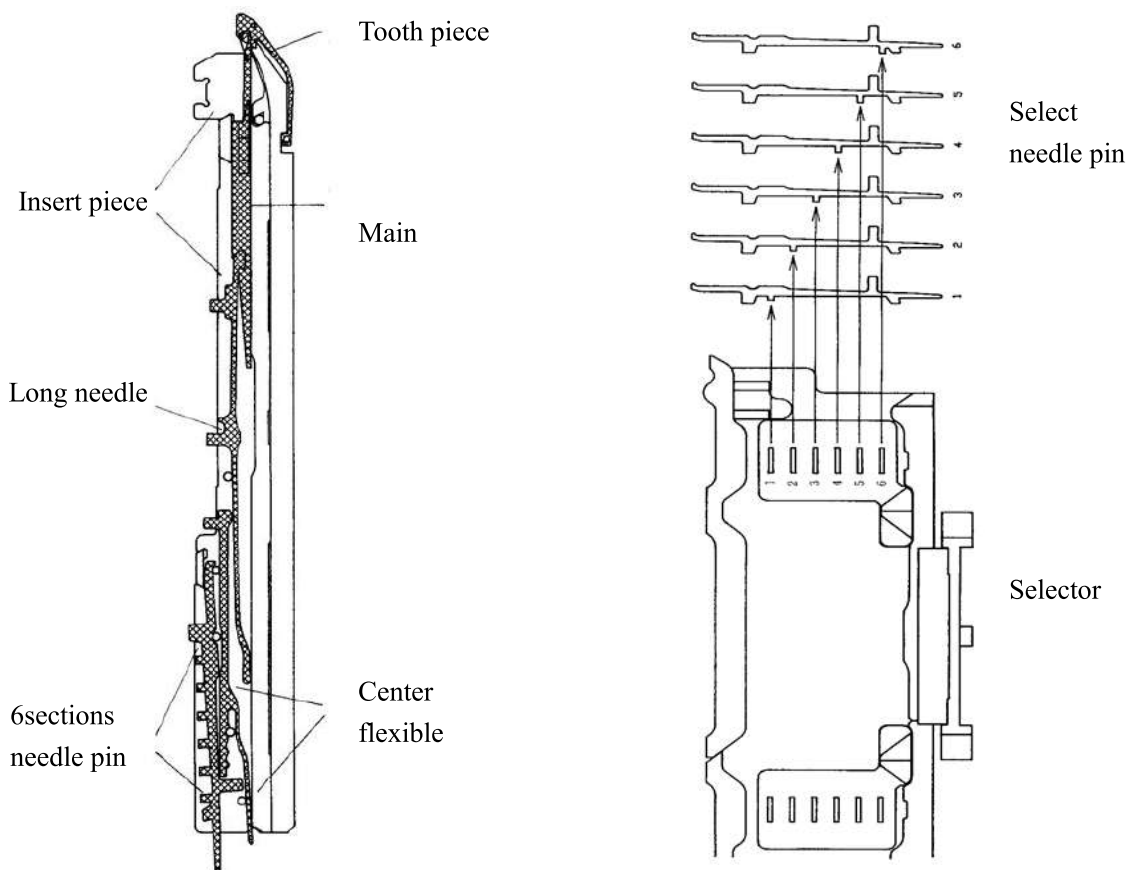

Non selector status

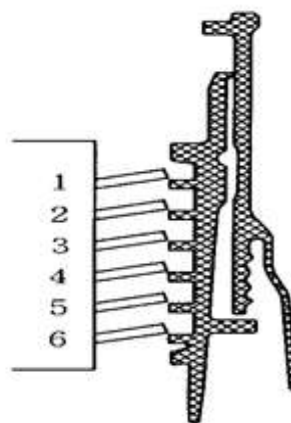

Selector status

2. Carriage cam structure (dual system)

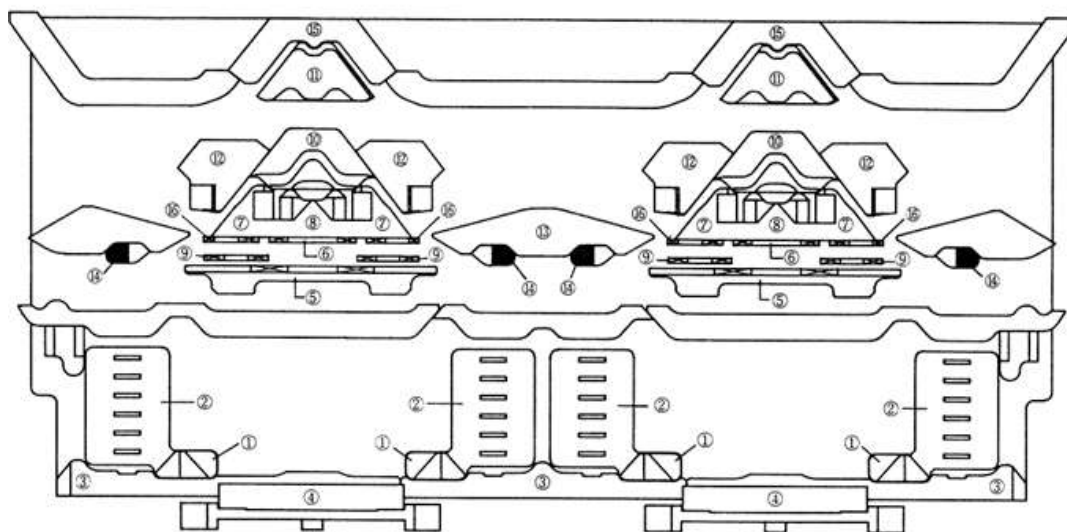

No	Name	Function
1	Select needle and push needle cam	Acting through needle selection re-election needle selection pins of the spring pin pushed to the A position
2	Needle selector acting on the select jack	Pre-selected or re-election 6 section needle pin needle selection to the position A or H position
3	Select and guide needle cam	Acting through needle selection re-election needle selection pins of the spring pin pushed to the H position
4	Needle selection homing cam	Make those are pressed needle pin of the needle selection back to the original position
5	Fixed non-knitting press	Acting on the pin of the needle selection of the B position, make it non- knitting
6	Tuck needle press	Acting on the pin of the needle selection of the H position, make it tuck
7	Push cam	Make pin will push to knit or tuck position
8	Get cam	When transfer the get pins running track cam
9	Half press	Acting on the pin of the needle selection of the H position, makes get when transfer or tuck in the 2section stitch
10	Center cam	Through the push cam (7) onto the knitting position pin along the track move down
11	Transfer guide	The cam makes needle pin up when transfer
12	Stitch cam	Up and down to adjust stitch
13	Guide cam	Makes the spring needle on A position move to H
14	Select and clear cam	Makes the spring needle on H position move to B
15	Transfer and guide cam	The function as the transfer and push cam, the cam makes transfer pin move down when transfer.
16	2 section stitch press	Effect the machine use 2 section stitch

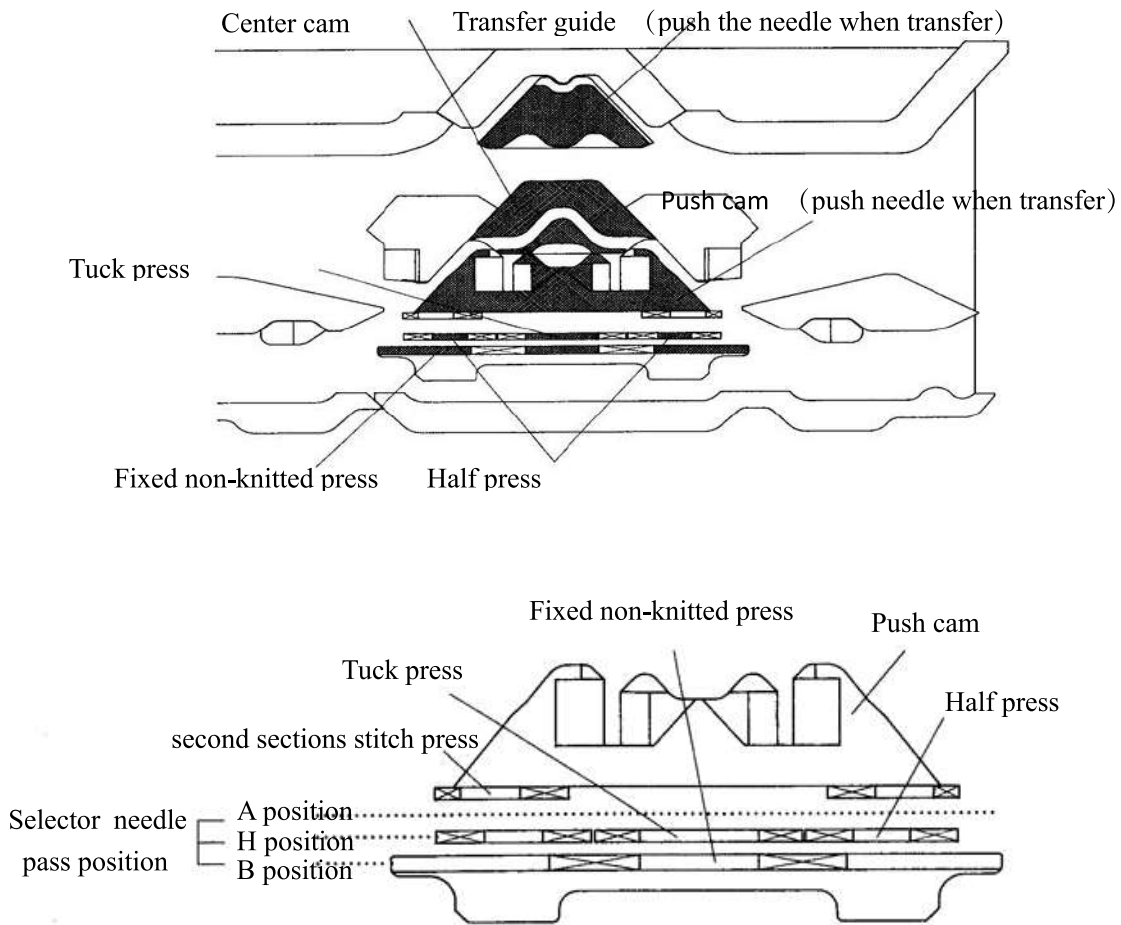

3. The cam action and needle channel direction

3.1 Knitting

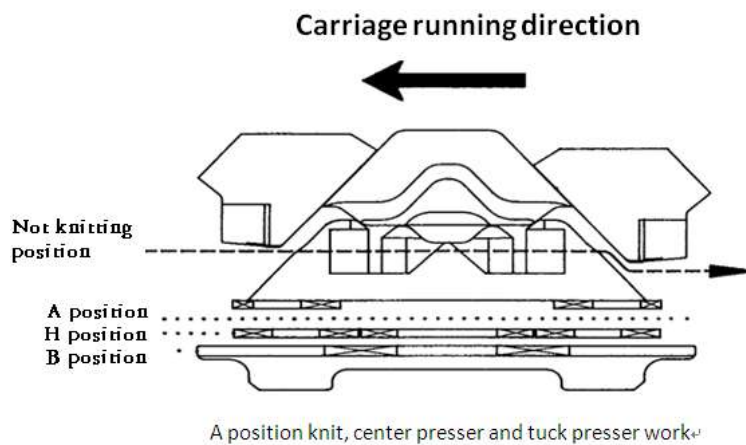

3.2 Non-knitting

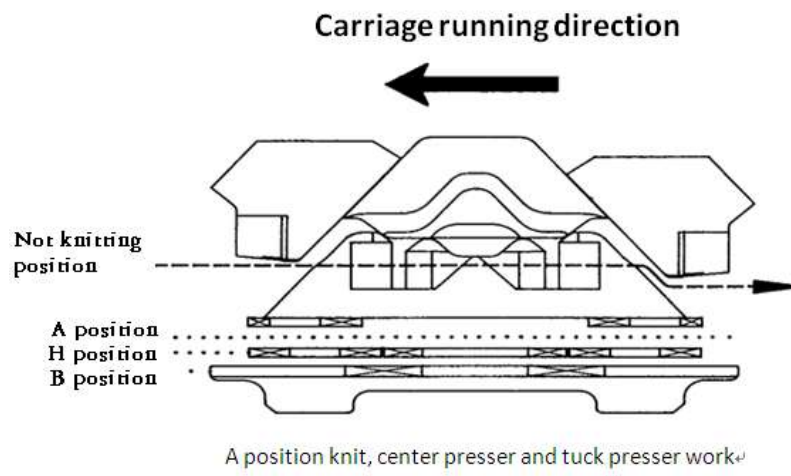

3.3 Transfer, Receive

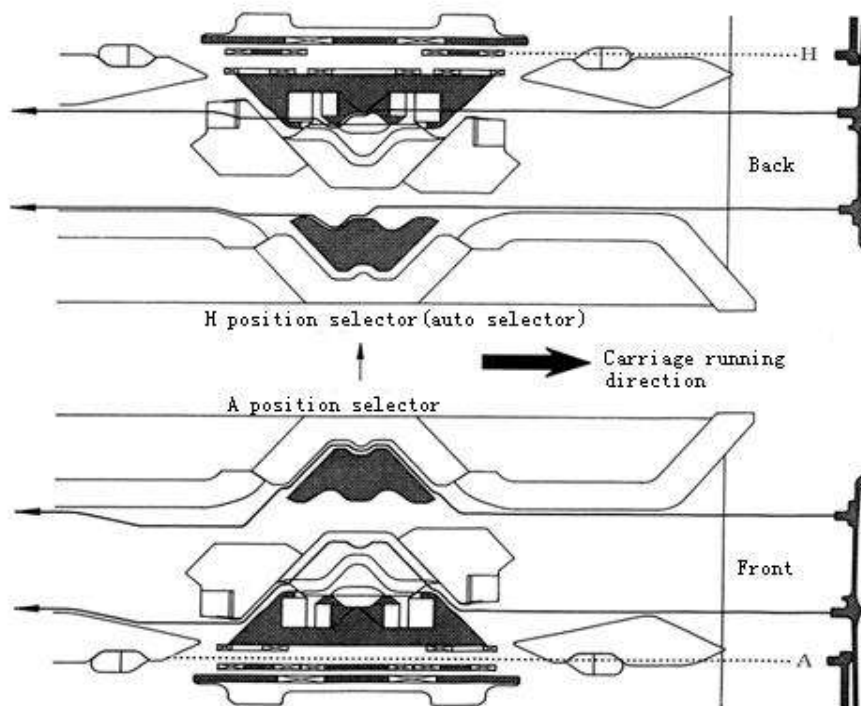

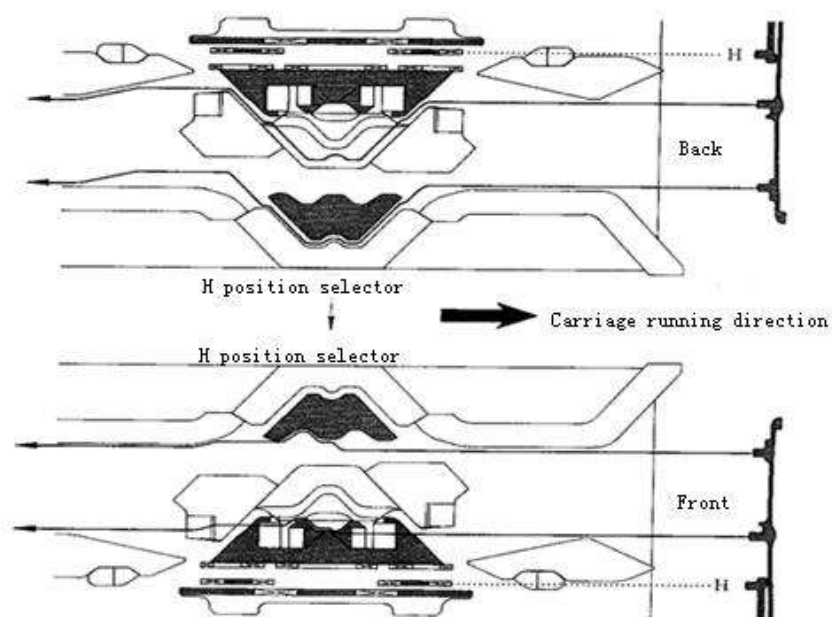

3.4 One of the dual system knit and the other get

